

HUBEN[®]
INSIDE

LENAGA[®]



FURNITURE FITTINGS & PVC SHEET

EDISI 05

Scan QR Code dibawah untuk mengikuti update terbaru dari Huben Indonesia!



Instagram Resmi
Huben Indonesia



 hubenindonesia



E-Katalog
Tarikan / Handle



Huben Indonesia



E-Katalog
PVC Sheet



Huben Indonesia

HUBEN

DAFTAR ISI

1

Ambalan

2-3

Bracket & Pipa Gantung

4-8

Engsel

9-12

Kunci

13-20

Lain-Lain

22

Minifix

23

LED Series

24-33

Profil Aluminium

34-46

Rel Laci

47-52

Roda Gantung & Roda Sliding

AMBALAN

AB-813

Ambalan Besi Bulat

Material : Besi
Finish : Nickel

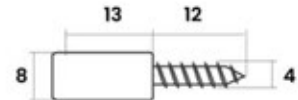

AJ-7

Ambalan Jepit (Skrup)

Material : Zinc Alloy
Finish : Nickel

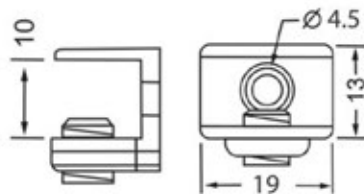

AJ-9

Ambalan Jepit (Pin)

Material : Zinc Alloy
Finish : Nickel

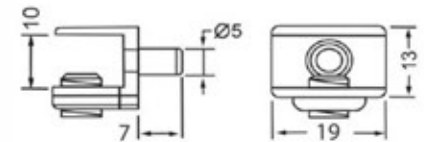

AKP-15-SS

Ambalan Kaca Plat

Material : Stainless Steel
Finish : Nickel

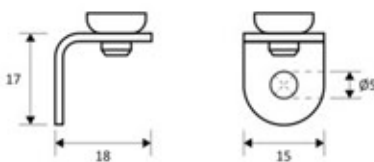

AKZ-14

Ambalan Kaca Zinc

Material : Zinc Alloy
Finish : Nickel

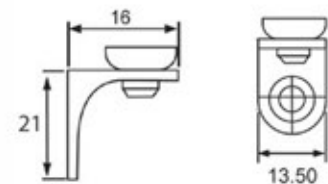

AK-06

Ambalan Karet

Material : Besi Plat
Finish : Galvanized

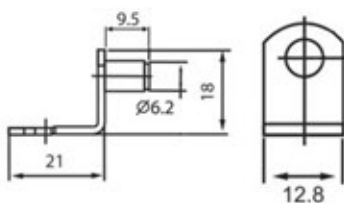

AK-04

Ambalan Tanpa Karet

Material : Zinc Alloy
Finish : Nickel

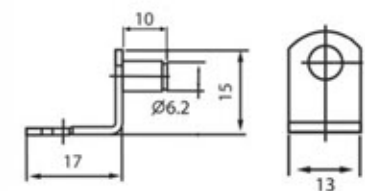

RH-13

Ambalan Kaca

Material : Zinc Alloy
Finish : Nickel

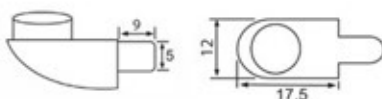

AB-5

Ambalan Bening

Material : Besi & Plastik
Finish : Galvanized

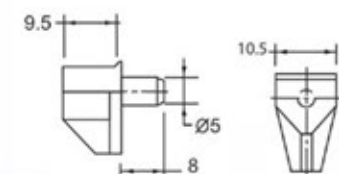

RH-21

Ambalan Besi Ring

Material : Besi
Finish : Nickel

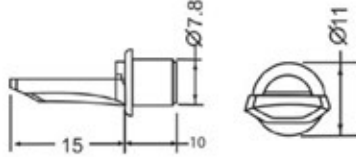

F-004

Ambalan Jepit Kaca

Material : Zinc Alloy
Finish : Nickel

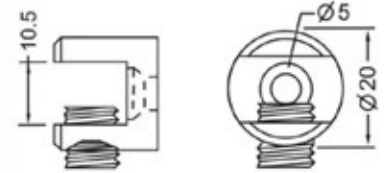

BRACKET & PIPA GANTUNG

Bracket :



BP-19 & 25



PT



PU

Bracket :



BP-16

HUBEN

STAINLESS STEEL

- PSS-19 & PSS-25
Pipa Bulat

Diameter : 19 & 25 mm
Panjang : 3 m

- PSS-1530
Pipa Oval

Diameter : 15 x 30 mm
Panjang : 3 m

HUBEN

BESI CHROME

- PBC-25
Pipa Bulat

Diameter : 25 mm
Panjang : 1.05 & 3 m

- PBC-1530
Pipa Oval

Diameter : 15x30 mm
Panjang : 3 m

LENAGA

STAINLESS STEEL

- LPS-25
Pipa Bulat

Diameter : 25 mm
Panjang : 3 m

- LPS-1530
Pipa Oval

Diameter : 15 x 30 mm
Panjang : 3 m



BP-16 Bracket Pipa Oval

Material : Zinc Alloy
 Finish : Nickel
 Diameter : 16 mm

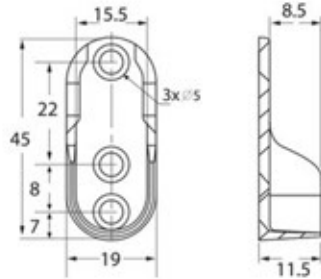

BP-19 & BP-25 Bracket Pipa Topi

Material : Zinc Alloy
 Finish : Chrome
 Diameter : 19 & 25 mm

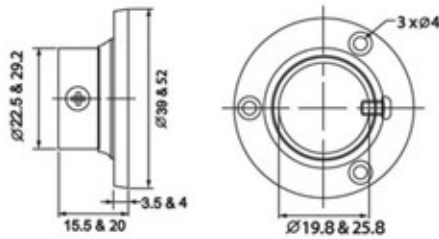

PT-19 & PT-25 Bracket Tiang Tengah

Material : Zinc Alloy
 Finish : Chrome
 Diameter : 19 & 25 mm

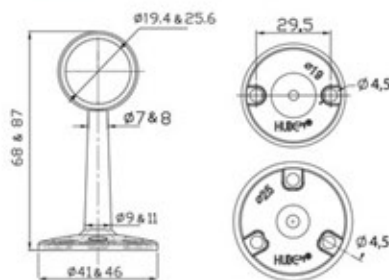

PU-19 & PU-25 Bracket Tiang Ujung

Material : Zinc Alloy
 Finish : Chrome
 Diameter : 19 & 25 mm

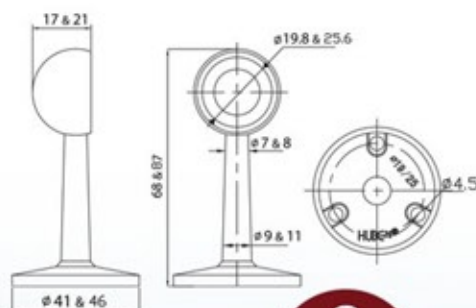



ENGSEL SENDOK

SLOW MOTION

LENAGA



Slow Motion

EK-L4 *Klip-on*

EK-0-L4
Lurus

EK-8-L4
Semi Bungkuk

EK-16-L4
Full Bungkuk



SLOW MOTION

HUBEN



Slow Motion

SM-L4 *Klip-on*

SM-0-L4
Lurus

SM-8-L4
Semi Bungkuk

SM-16-L4
Full Bungkuk



Material : Besi Plat
Finish : Nickel

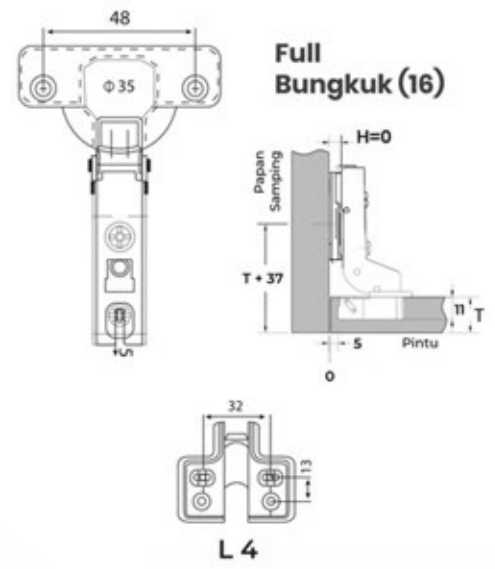
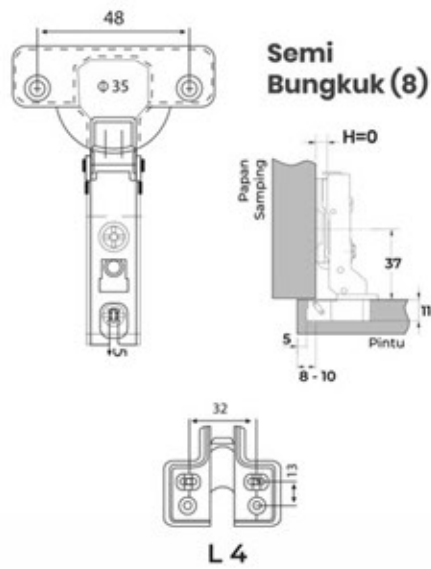
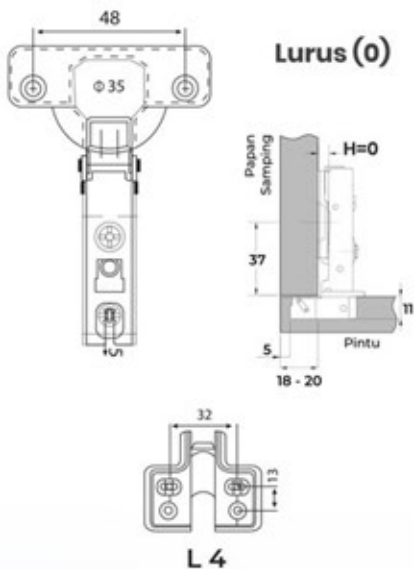



Slow Motion

Engsel Sendok 165° Slow-Motion

E-180-SM-0
Lurus

E-180-SM-8
Semi Bungkuk

E-180-SM-16
Full Bungkuk

Material : Besi Plat
Finish : Nickel

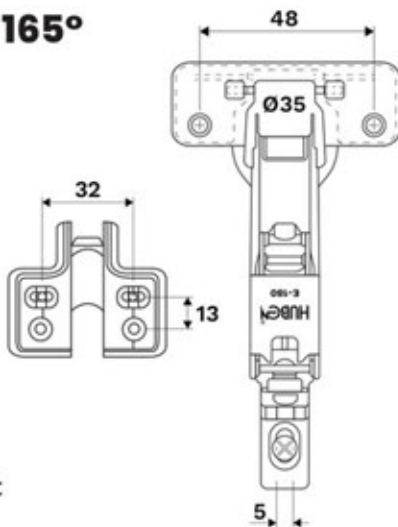

Engsel Bifold 135°

BIFOLD-135

Material : Besi Plat
Finish : Nickel

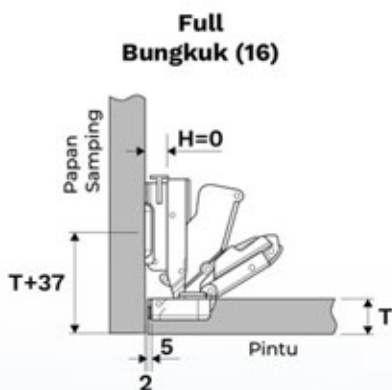
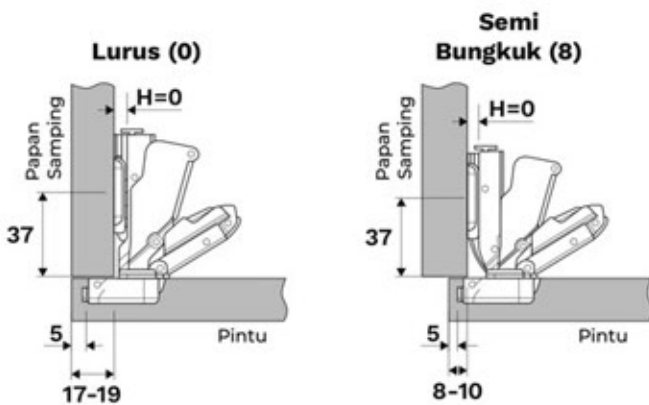
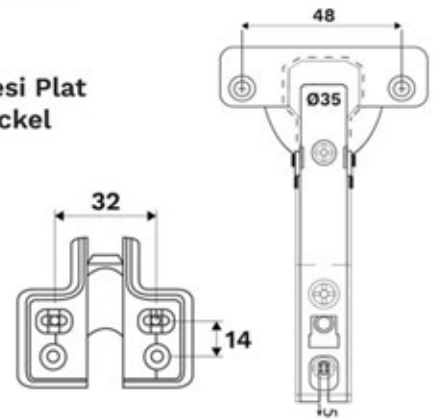

KOMBINASI E-180-SM & BIFOLD-135

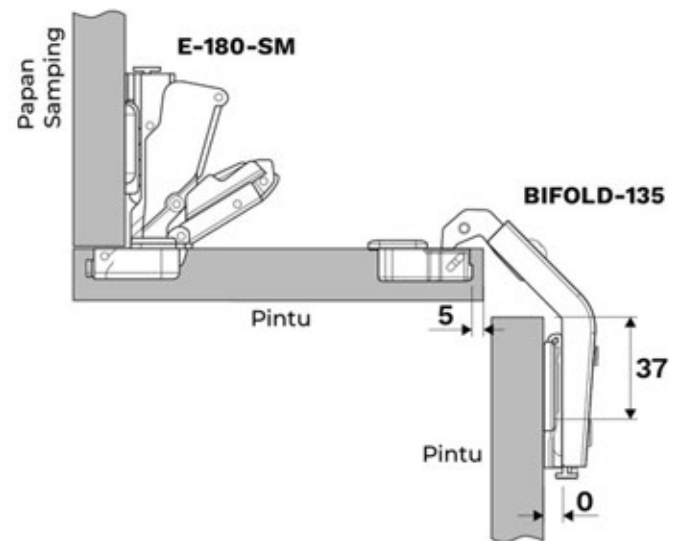

Engsel Sendok Slow Motion *Klip-on // STAINLESS STEEL*

SUS-0
Lurus

SUS-8
Semi Bungkok

SUS-16
Full Bungkok

Material : Stainless Steel 304
Finish : Stainless Steel

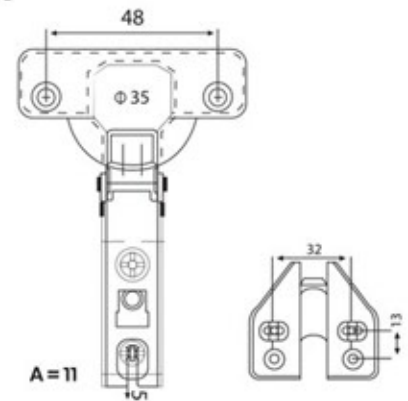

Stainless Steel

Slow Motion



Engsel Sendok Slow Motion *Klip-on*

AP-0-L4
Lurus

AP-8-L4
Semi Bungkok

AP-16-L4
Full Bungkok

Material : Besi Plat
Finish : Nickel

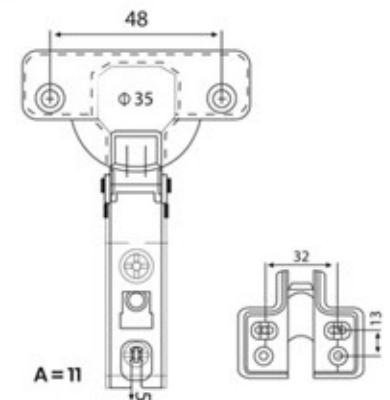

Slow Motion



Engsel Sendok *Slide-on*

HT-0
Lurus

HT-8
Semi Bungkok

HT-16
Full Bungkok

Material : Besi Plat
Finish : Nickel

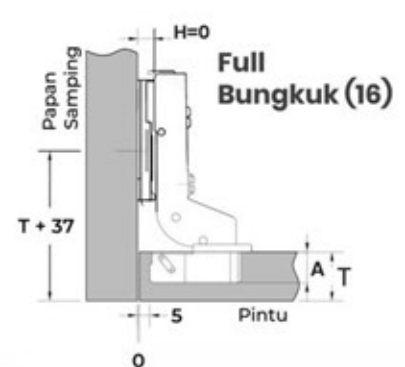
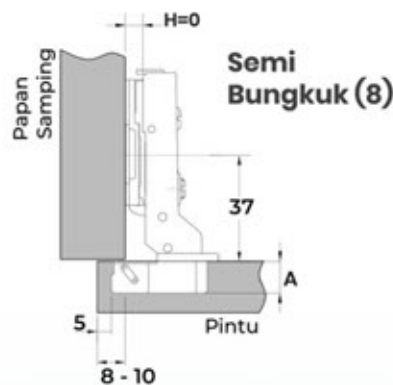
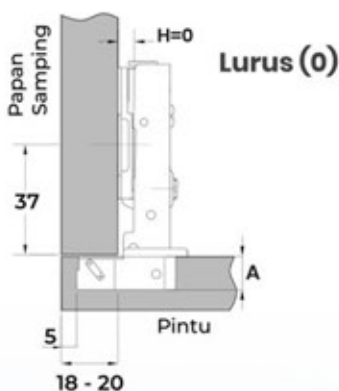
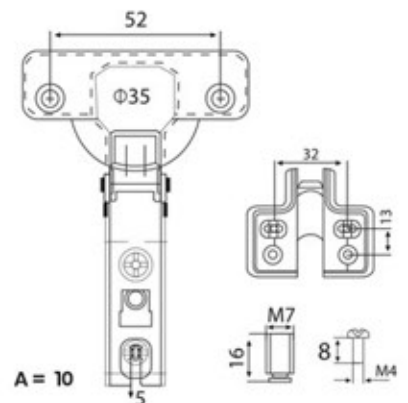



Engsel Sendok Slide-on

HB-0
Lurus

HB-8
Semi Bungkuk

HB-16
Full Bungkuk

Material : Besi Plat
Finish : Nickel

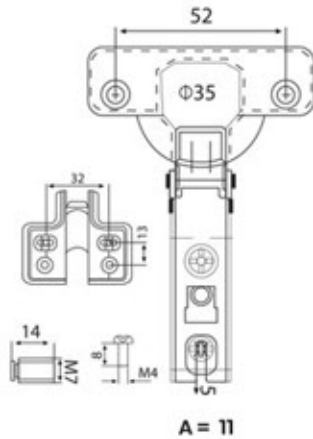

Engsel Sendok Slide-on

MT-0
Lurus

MT-8
Semi Bungkuk

MT-16
Full Bungkuk

Material : Besi Plat
Finish : Nickel

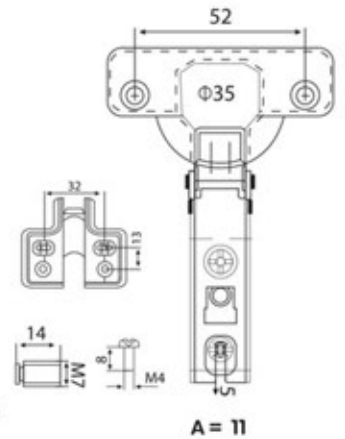

Mini

Engsel Sendok Mini Slide-on

MH-0
Lurus

MH-8
Semi Bungkuk

MH-16
Full Bungkuk

Material : Besi Plat
Finish : Nickel

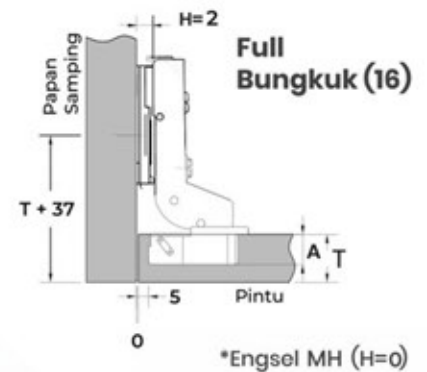
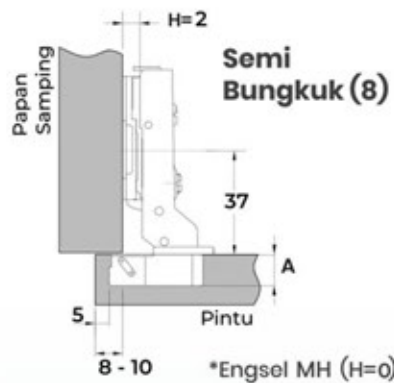
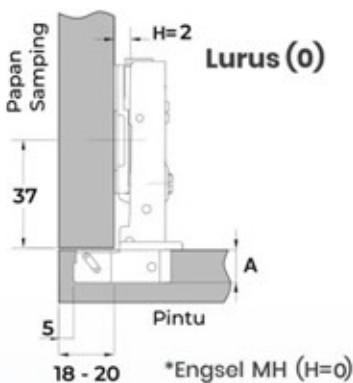
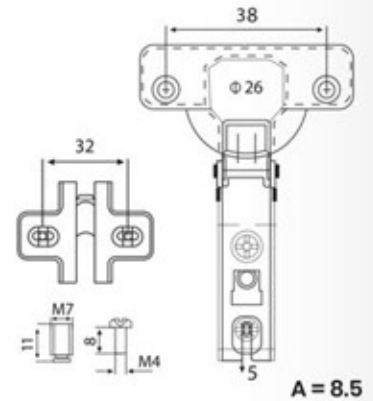



Engsel Sendok Kaca Key Hole

GH-0
Lurus

GH-16
Full Bungkok

Material : Besi Plat
Finish : Nickel

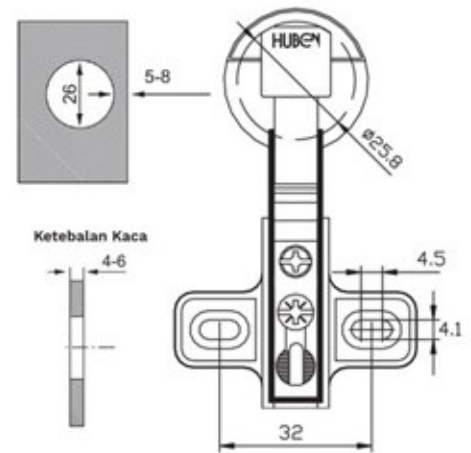

Engsel Sendok Kaca Slide On

HEK-0
Lurus

HEK-16
Full Bungkok

Material : Besi Plat
Finish : Nickel

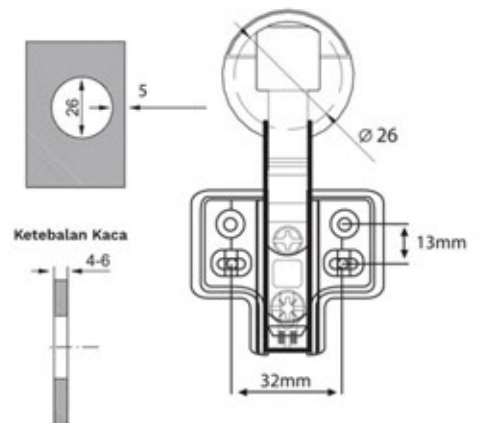

Slow
Motion

Engsel Sendok Kaca Slow Motion Klip On

KS-0
Lurus

KS-16
Full Bungkok

Material : Besi Plat
Finish : Nickel

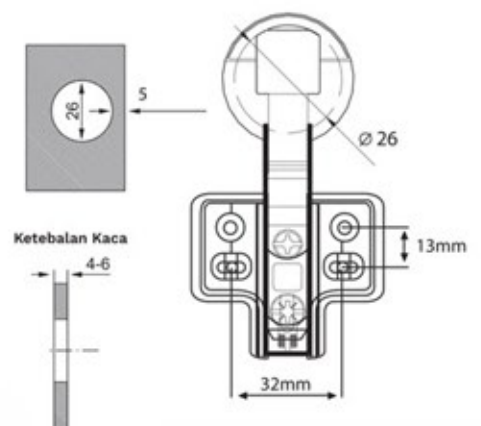



KUNCI

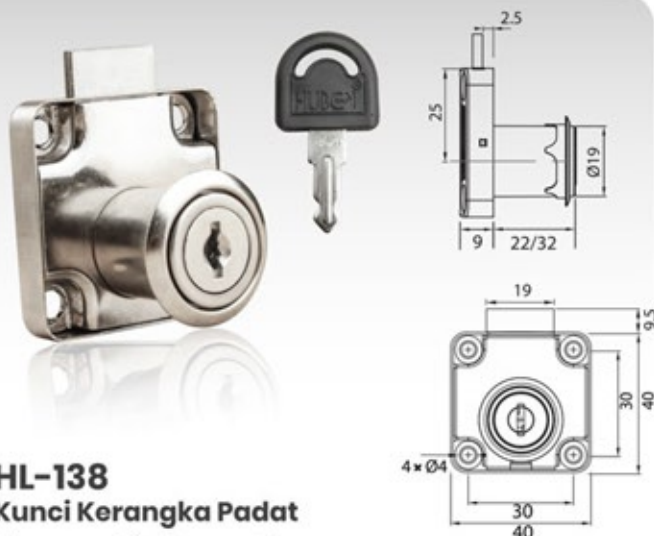

HL-138
Kunci Kerangka Padat

Diameter Silinder : 19 mm
 Panjang Silinder : 22 mm & 32 mm
 Material Silinder : Zinc Alloy & Besi
 Material Kerangka : Plat Besi

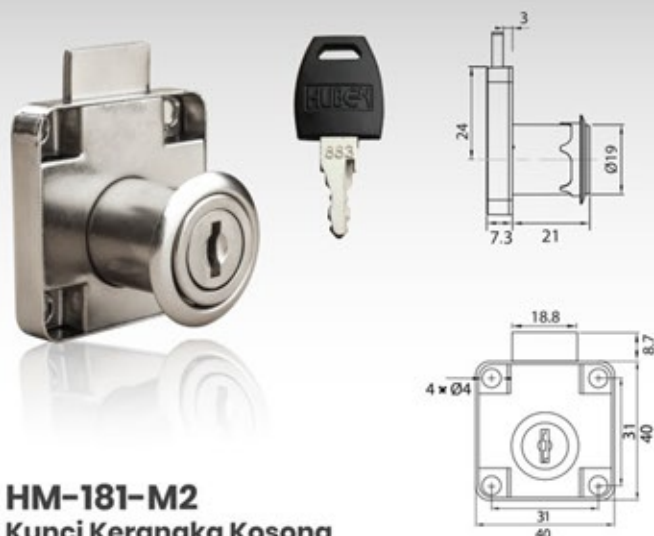

HM-181-M2
Kunci Kerangka Kosong

Diameter Silinder : 19 mm
 Material Silinder : Zinc Alloy
 Material Kerangka : Plat Besi

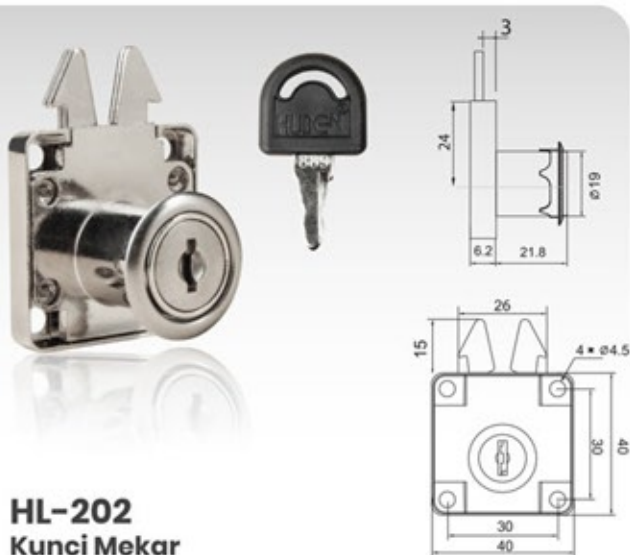

HL-202
Kunci Mekar

Diameter Silinder : 19 mm
 Material Silinder : Zinc Alloy
 Material Kerangka : Zinc Alloy

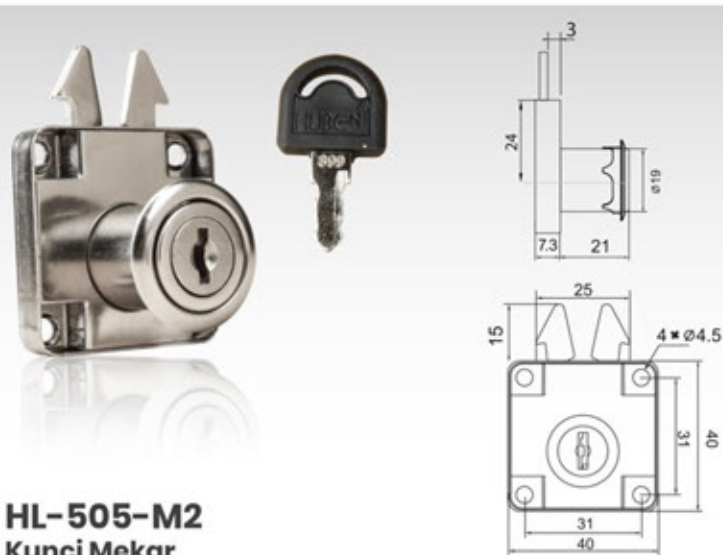

HL-505-M2
Kunci Mekar

Diameter Silinder : 19 mm
 Material Silinder : Zinc Alloy
 Material Kerangka : Plat Besi



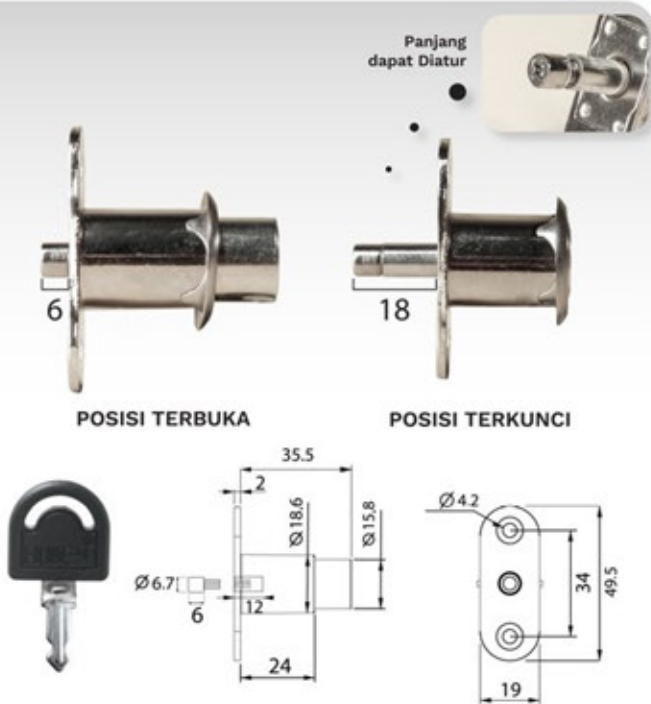

HL-105 Kunci Tekan (Push Lock)

Diameter Silinder : 19 mm
Material Silinder : Zinc Alloy
Material Kerangka : Zinc Alloy



HL-103 Kunci Camlock

Diameter Silinder : 19 mm
Panjang Silinder : 16, 20, 25, 30, 32 mm
Material Kerangka : Zinc Alloy



HL-701 Kunci Kaca Kait Single

Diameter Silinder : 20 mm
Material Silinder : Zinc Alloy
Material Kerangka : Zinc Alloy
Untuk Ketebalan Kaca : 4-8 mm



HL-702 Kunci Kaca Kait Double

Diameter Silinder : 20 mm
Material Silinder : Zinc Alloy
Material Kerangka : Zinc Alloy
Untuk Ketebalan Kaca : 4-8 mm



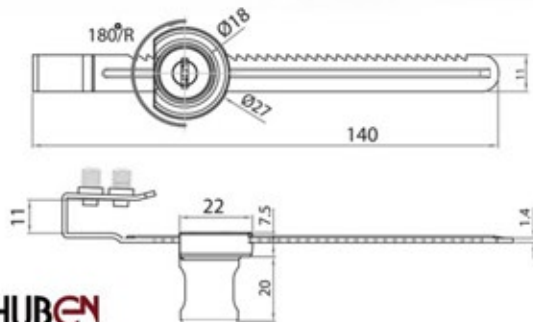

HUBEN
HL-140
Kunci Gergaji

Diameter Silinder : 18 mm
Material Silinder : Zinc Alloy
Panjang Gergaji : 140 mm

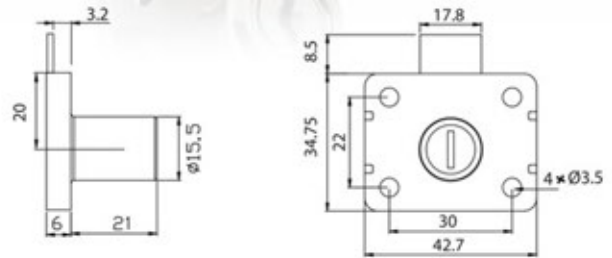

HUBEN
HL-303
Kunci Laci

Diameter Silinder : 16 mm
Material Silinder : Zinc Alloy
Material Kerangka : Plat Besi

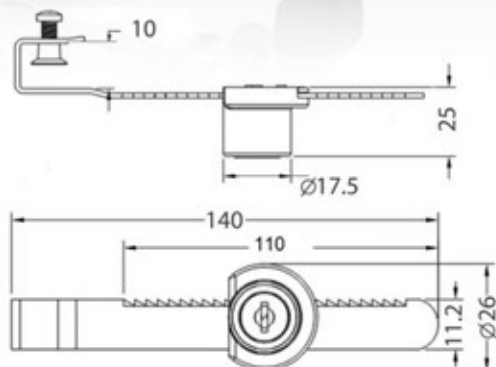

LENAGA
LE-135
Kunci Gergaji

Diameter Silinder : 18 mm
Material Silinder : Zinc Alloy
Panjang Gergaji : 140 mm

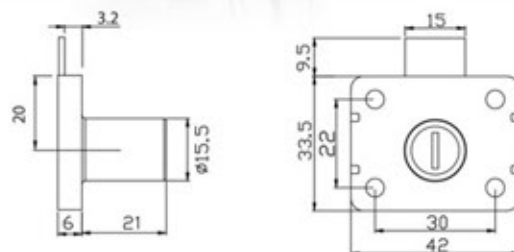

LENAGA
LE-303
Kunci Laci

Diameter Silinder : 16 mm
Material Silinder : Nylon
Material Kerangka : Plat Besi



HL-108 Kunci Central Samping



Diameter Silinder : 19 mm
Panjang Tiang : 60 cm

Material Silinder : Zinc Alloy
Material Tiang : Aluminium

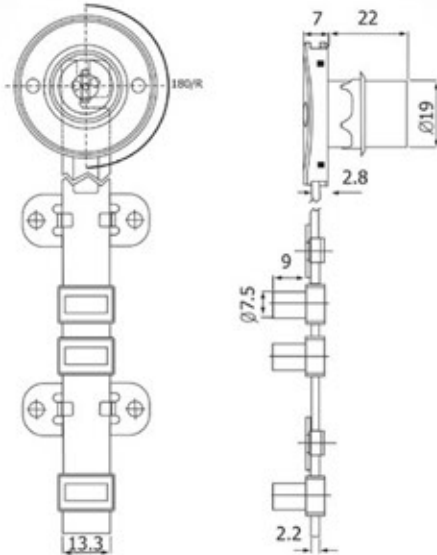
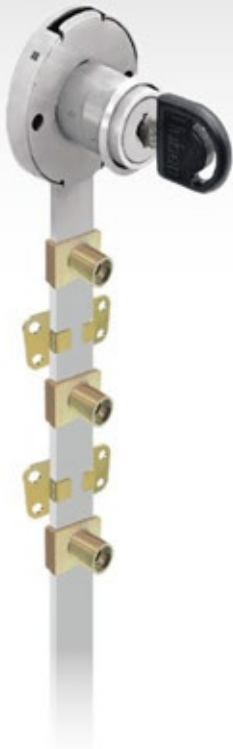

HL-288 Kunci Central Depan Silinder dan Tiang



Diameter Silinder : 19 mm
Panjang Tiang : 60 cm

Material Silinder : Zinc Alloy
Material Tiang : Aluminium

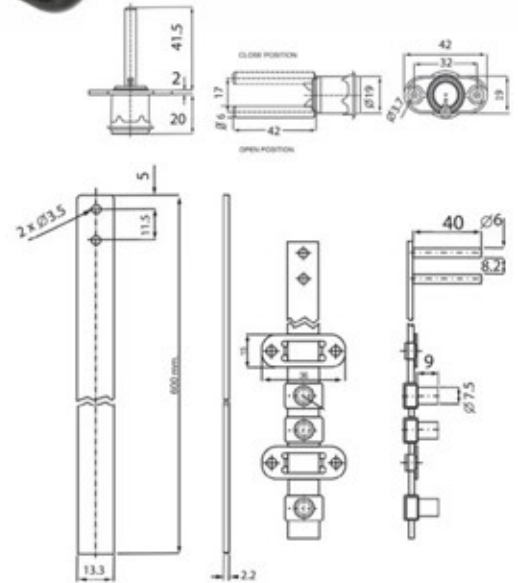
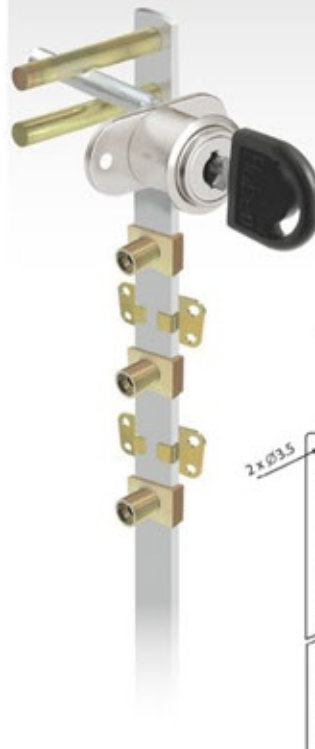

HL-690 Kunci Espagnolette



Diameter Silinder : 18 mm
Panjang Tiang : 100 & 130 cm
Material Silinder : Zinc Alloy
Material Tiang : Besi
Material Kerangka : Zinc Alloy

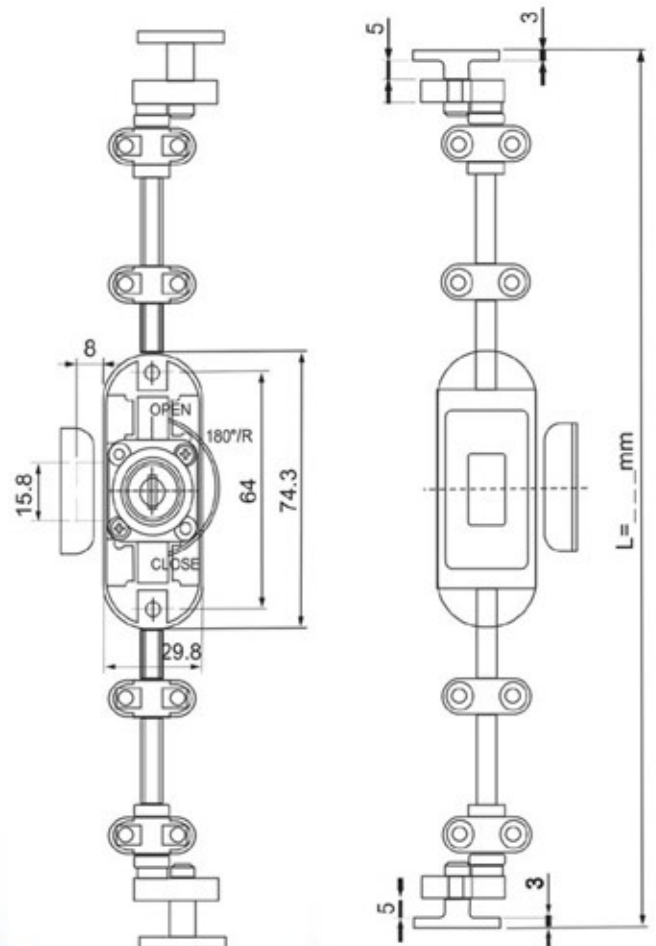
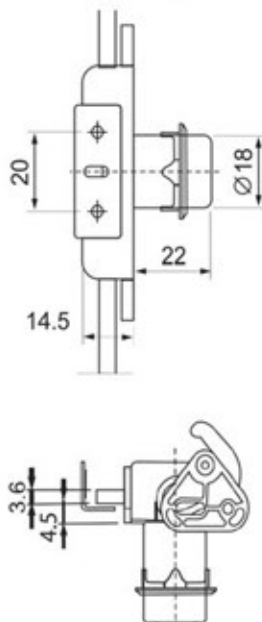

LAIN-LAIN



WL-115
Junior Lift

Warna : Silver, Hitam
Kapasitas Beban : 12 Kg

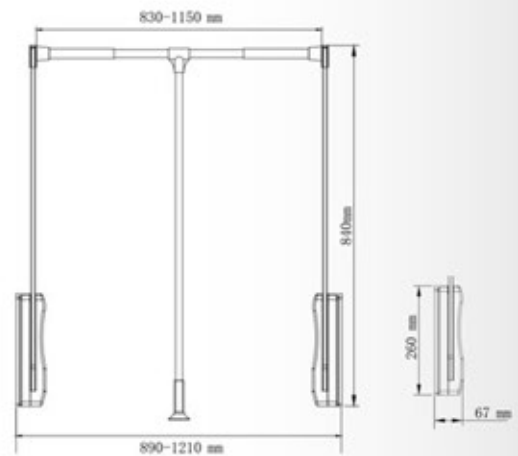

Slow Motion



WL-200-SM
Wardrobe Lift Slow Motion

Warna : Silver, Hitam
Kapasitas Beban : 10 Kg

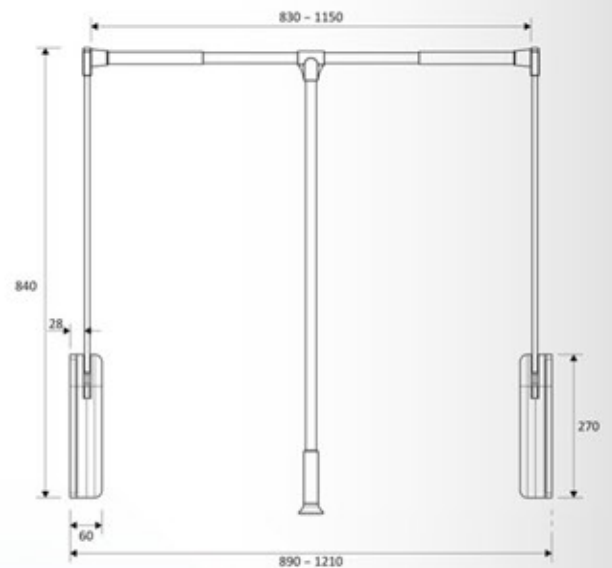



Tip On

Warna : Abu, Putih



TO-1

Plat Bulat

TO-2

Plat Persegi



Tip On *Stainless Steel*

TO-3-SS Plat Bulat



FURNITURE PVC SHEET



E-Katalog
PVC Sheet

Ketebalan : 0.3 mm

Kode Barang : PL, SK



Form Request
Katalog **GRATIS**



Lubang Udara Aluminium

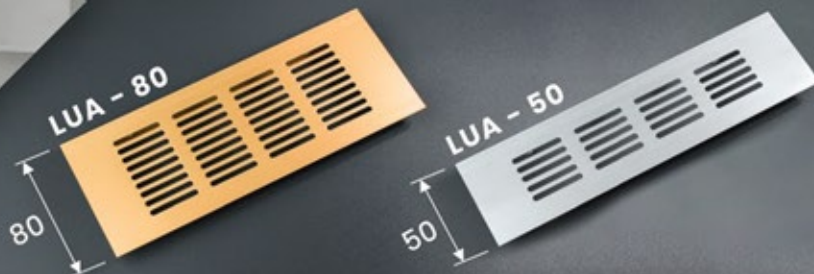

LUA-50

Finish: Anodize, Hitam, Gold

Panjang A : 150 - 200 - 250 - 300

Panjang B : A - 30

LUA-80

Finish: Anodize

Panjang A : 150 - 200 - 250 - 300 - 350 - 400

Panjang B : A - 30

Finish: Hitam, Gold

Panjang A : 150 - 200 - 250 - 300

Panjang B : A - 30

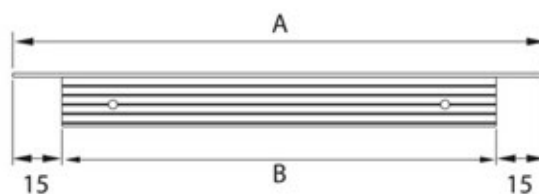
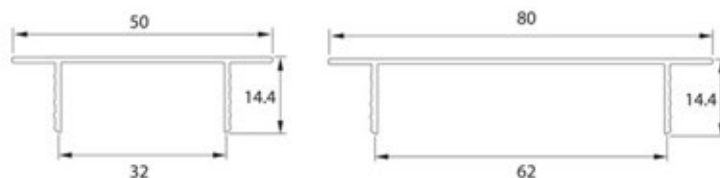

Dalam satuan milimeter (mm)



GS Gas Spring

Mini 60N, 60N, 80N, 100N, 150N

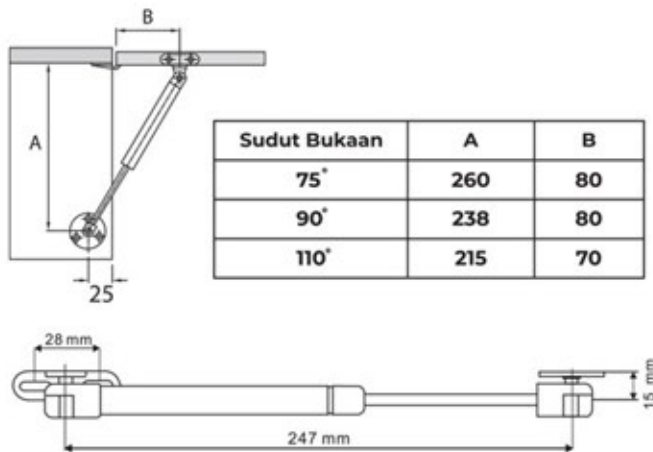

GSM Gas Spring Slow Motion

60N, 80N, 100N, 150N

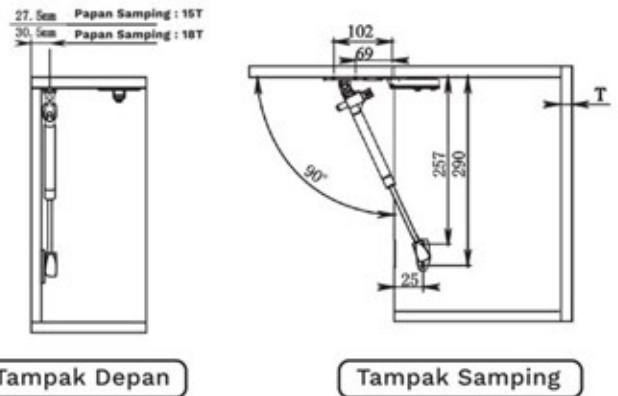

KM Ring Meja Aluminium

Diameter : 200, 300, 400, 500 mm

	T	A	B
KM 200	10	200	145
KM 300	10	300	245
KM 400	11	400	335
KM 500	12	500	430

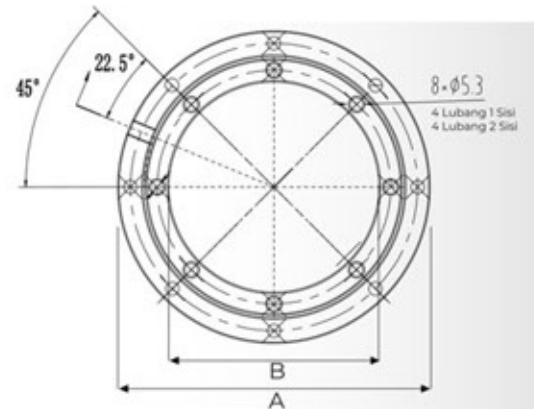

PIK Pen Iklan SS

Diameter (D)	Tinggi (T)
12	20, 25, 30
16	20, 25, 30
19	20, 25, 30, 40, 50
25	25, 30, 40, 50
30	30, 40, 50

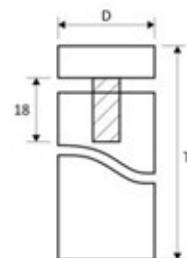

Dalam satuan millimeter (mm)



ETRIM-40
Edging Trimmer SS

Material : Stainless Steel

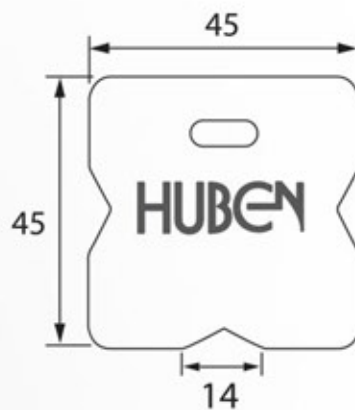

GP-27
Grendel Tekan

Warna : Coklat

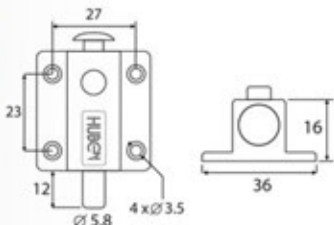

PS-17
Push Single

Material : Plat Besi
Finish : Chrome

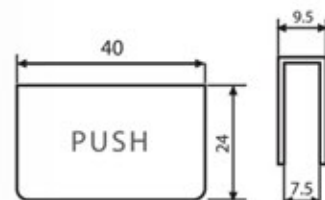

T-86
Engsel Kaca Jepit

Finish : Chrome

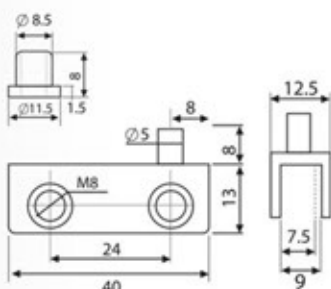

TR-40
Trapes

Warna : Putih & Coklat

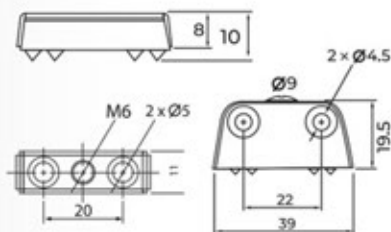

MS-31
Magnet Single

PS-17
Push Single

MP-46
Magnet Persegi Besar



MS-31
Magnet Single

Warna : Hitam

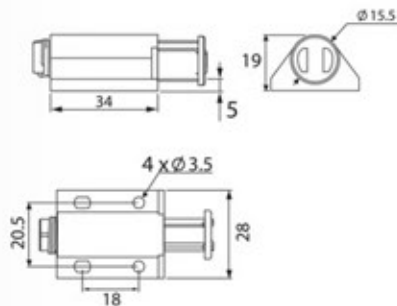

MD-32
Magnet Double

Warna : Hitam

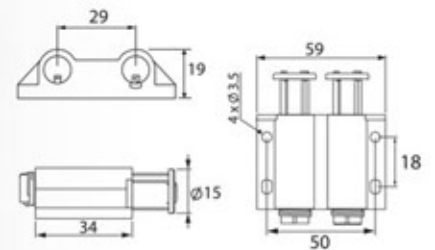

MP-33
Magnet Persegi

Warna : Coklat, Putih

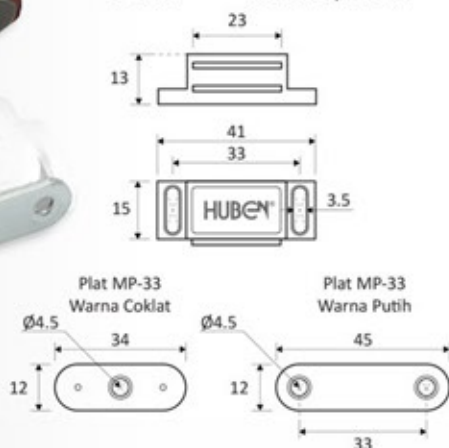

MP-46
Magnet Persegi Besar

Warna : Coklat, Putih

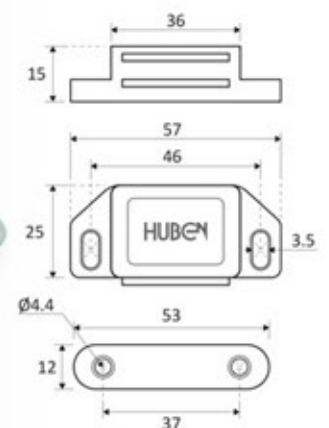



RP Rak Piring Gantung Stainless

Ukuran : 600, 700, 800,
900, 1000 mm.

Kode Barang	Ukuran Rak Piring P x L x T	Ukuran Lebar Lemari
RP-600-SS	565 x 280 x 65	600
RP-700-SS	665 x 280 x 65	700
RP-800-SS	765 x 280 x 65	800
RP-900-SS	865 x 280 x 65	900
RP-1000-SS	965 x 280 x 65	1000

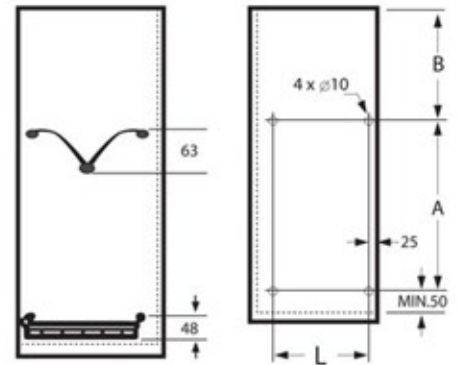

SA-45 Siku Frame Aluminium

Material : Aluminium

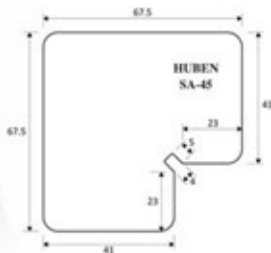

AH-45 Siku Frame Aluminium

Material : Plat Besi

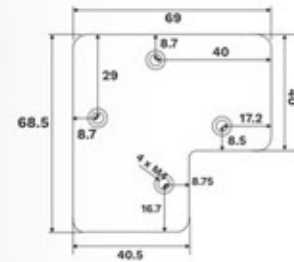

BOS-447 Skrup Patah-Patah

Ukuran : M4 x 47 mm

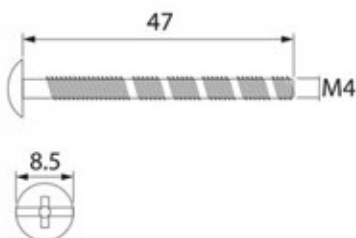

Skrup-701 Baut Siku AH

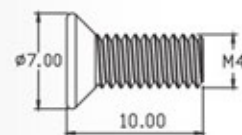

SK-HF Skrup Kaca Chrome

Ukuran Ø : 10, 12, 14, 16, 18 mm



SKSS Skrup Kaca Stainless

Ukuran Ø : 16, 19, 22, 25, 30 mm



RD-2-BC Rak Dapur 2 Susun



Material : Besi Chrome
Ukuran : 300, 400



Ukuran Kabinet (L)	Ukuran Rak Dapur P x L x T (mm)
300	480 x 225 x 474
400	480 x 325 x 474

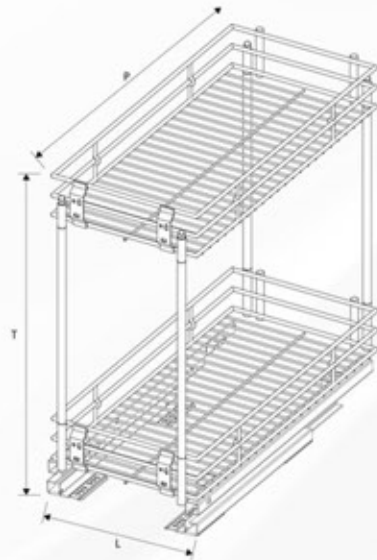

KP-01-BC Kerangka Piring



Material : Besi Chrome

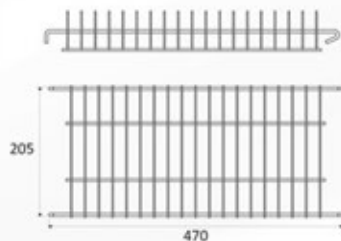
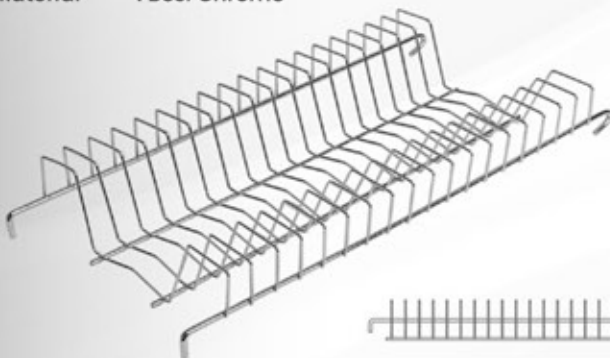

KB-02-BC Kerangka Botol



Material : Besi Chrome

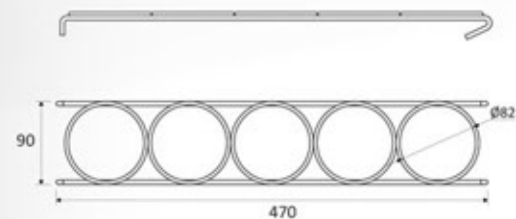



RD-3-BC Rak Dapur 3 Susun



Material : Besi Chrome
Ukuran : 300, 400

Ukuran Kabinet (L)	Ukuran Rak Dapur P x L x T (mm)
300	480 x 225 x 474
400	480 x 325 x 474



HUBEN

Minifix



MF-10-G
Casing Minifix
Material : Zinc Alloy

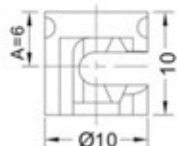

MF-105
Casing Minifix
Material : Zinc Alloy



MF-15-G
Casing Minifix
Material : Zinc Alloy

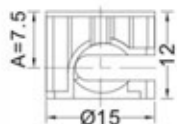

HG-624
Skrup Minifix
Material : Besi

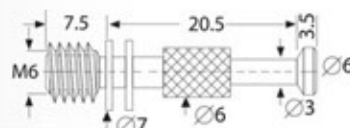

KSF-5533-9
Skrup Minifix
Material : Besi

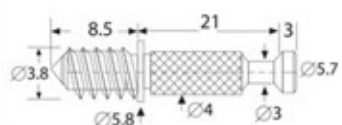

KSF-6536-11
Skrup Minifix
Material : Besi

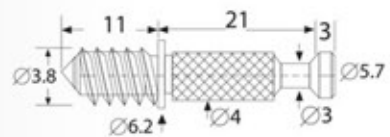

DU-6249
Skrup Minifix
Material : Besi

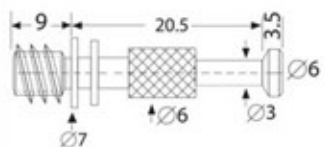

DU-62411
Skrup Minifix
Material : Besi

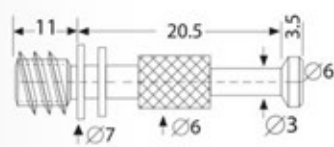

NS-10, NS-10-B
Nylon Socket - M6 x 10 mm

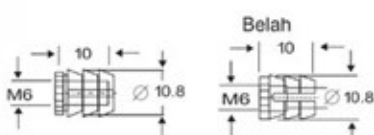

DO-02
Camfix
Warna : Coklat
Material : Plastic + Zinc Alloy

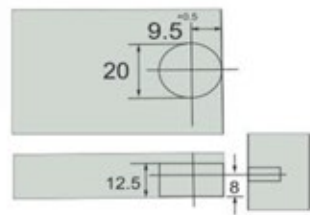

Fisher
FIS-59 5 x 9 mm (Merah)
FIS-512 5 x 12 mm (Putih)

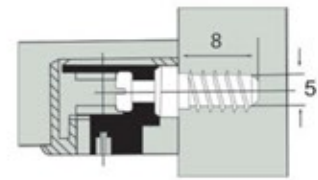
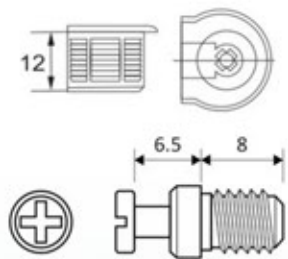
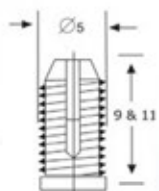

HUBEN LIGHTING

DR-60-W

Driver LED untuk RULAM-10
60W 12V



RULAM-10-LED

Termasuk Lampu LED Strip 4000K
130 MATA LAMPU / METER

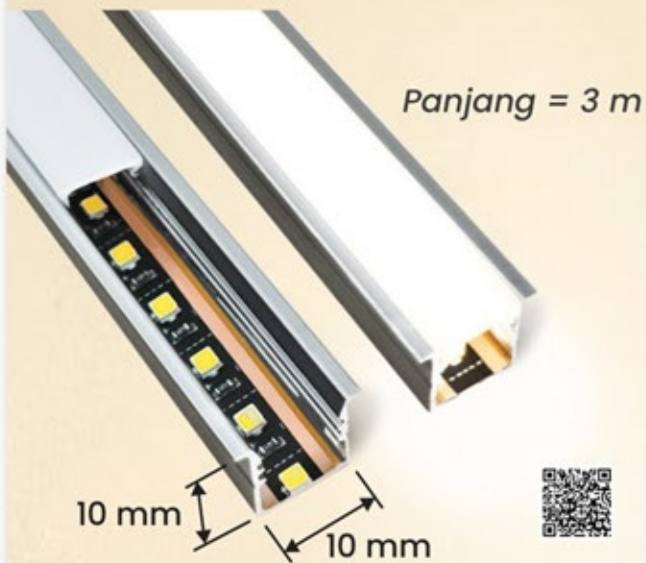

KABEL-10

Kabel RULAM-10 dan Aksesoris



Bracket



Penutup



SENSOR-P-1

Sensor Lampu Pintu Single



Dilengkapi
Perekat

SENSOR-P-2

Sensor Lampu Pintu Double



PROFIL ALUMINIUM & STAINLESS STEEL

• Panjang 3 Meter

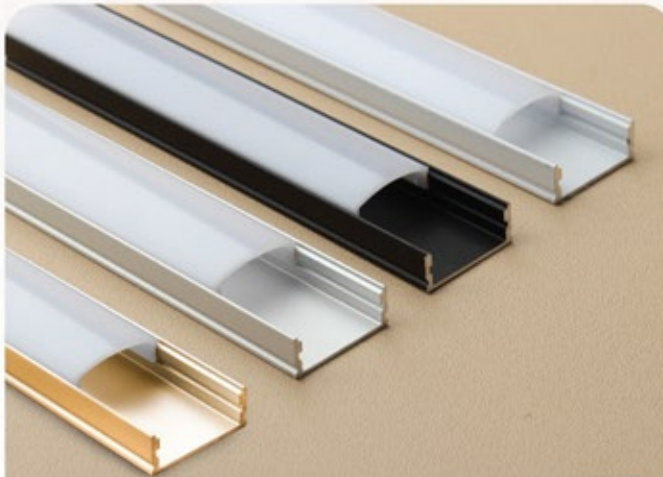

Rumah Lampu LED Strip
RULAM-17

- Anodize
- Putih
- Hitam
- Gold Mirror

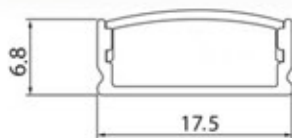

Rumah Lampu LED Strip
RULAM-24

- Anodize
- Putih
- Hitam
- Gold Mirror

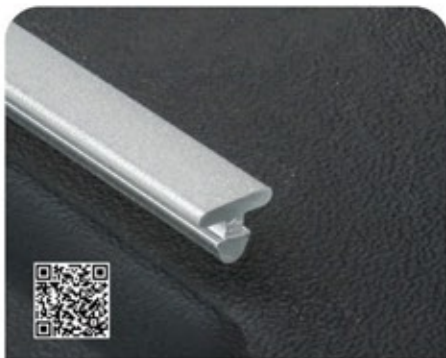
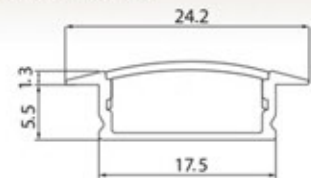

LT-06

- Anodize
- Silver Pasir

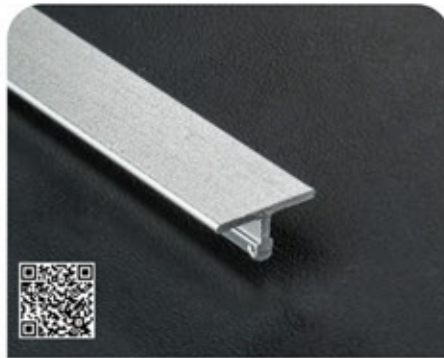
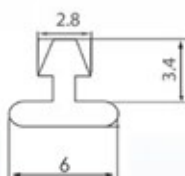

LT-08 & LT-12

- Anodize
- Silver Pasir
- SS
- Hitam
- Mirror
- Gold Mirror

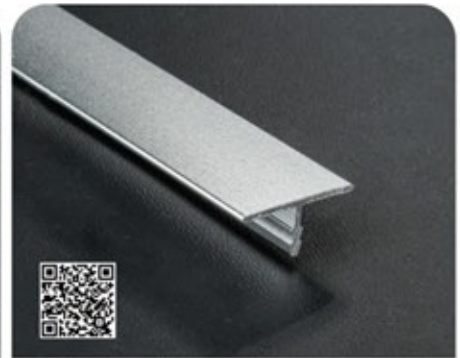
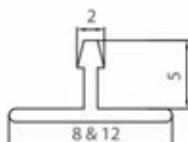

LT-15 & LT-18

- Anodize
- Silver Pasir
- SS
- Hitam
- Mirror
- Gold Mirror

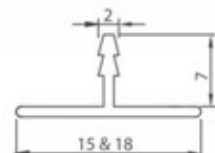

• Panjang 3.05 Meter

• Bahan : Stainless Steel



Plat Strip RATA PSR

- Black Mirror
- Mirror
- Gold Mirror
- Rose Gold

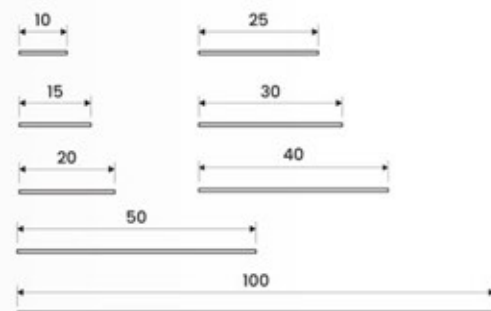

Tersedia Ukuran (mm)

- 10
- 15
- 20
- 25
- 30
- 40
- 50
- 100



Plat Strip L PSL

- Black Mirror
- Mirror
- Gold Mirror
- Rose Gold

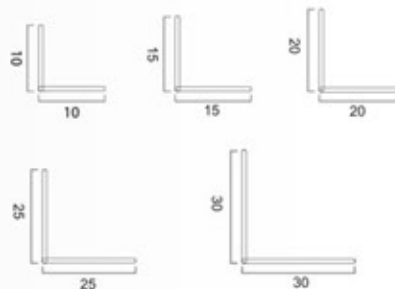

Tersedia Ukuran (mm)

- 10 x 10
- 15 x 15
- 20 x 20
- 25 x 25
- 30 x 30



Plat Strip U PSU

- Black Mirror
- Mirror
- Gold Mirror
- Rose Gold

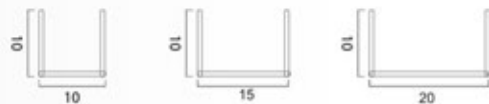

Tersedia Ukuran (mm)

- 10 x 10 x 10
- 10 x 15 x 10
- 10 x 20 x 10

Contoh Pengaplikasian Plat Strip

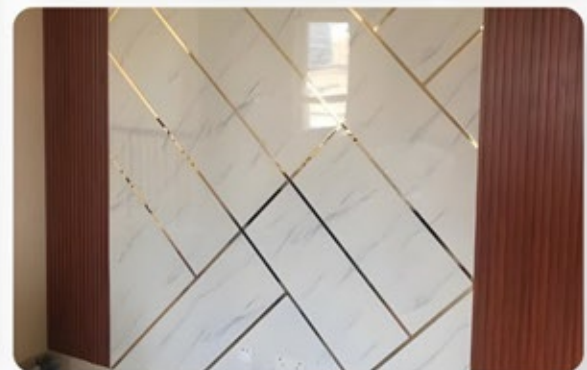
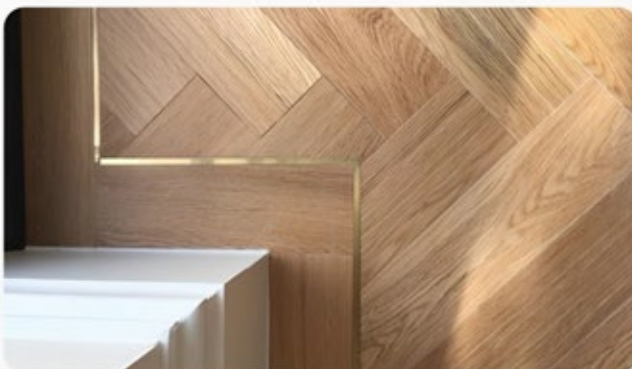

• Panjang 3 Meter

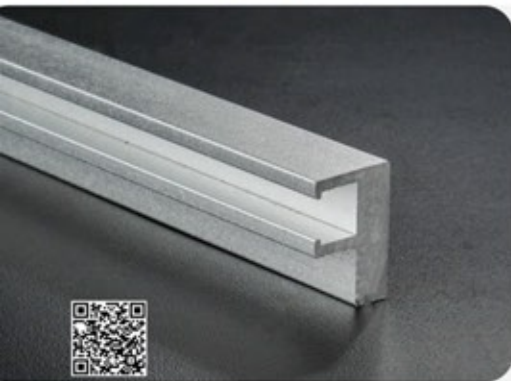

FA-19

- Anodize
- Brush
- Silver Pasir

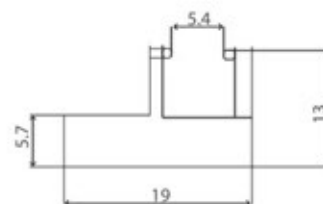

FA-32

- Anodize
- Brush

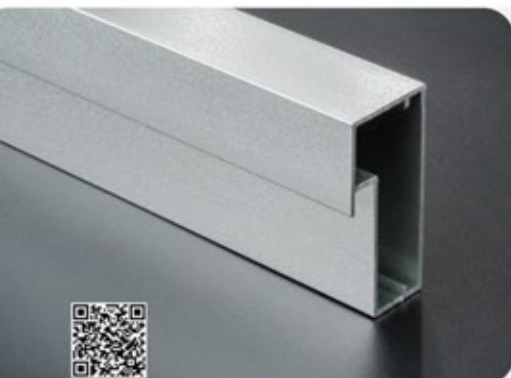
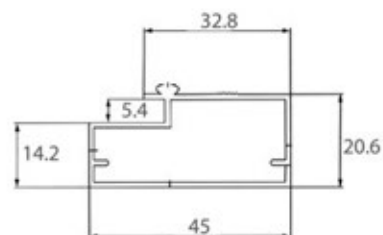

FA-45

- Brush
- Silver Pasir
- SS

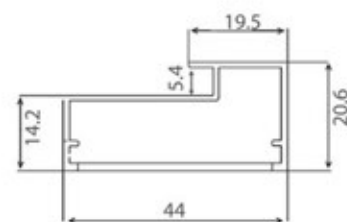

FA-128

- Anodize
- Brush
- Silver Pasir
- SS
- Hitam
- Mirror
- Gold Mirror

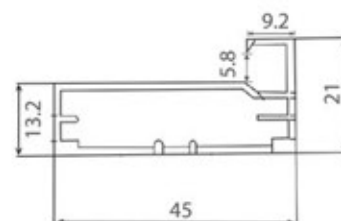

LENAGA LEFA-128

- Anodize
- Mirror
- Silver Pasir
- SS
- Hitam
- Gold Mirror

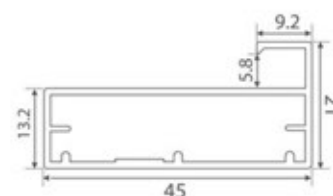

• Panjang 3 Meter

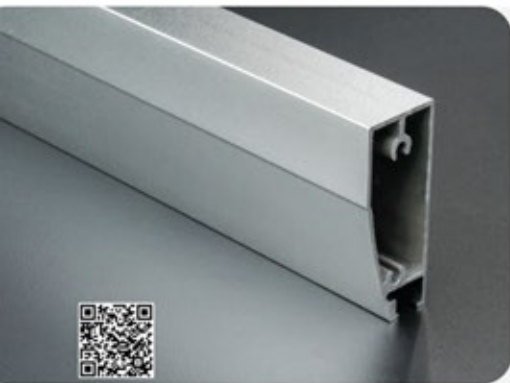

FA-48

- Anodize
- Brush
- Silver Pasir

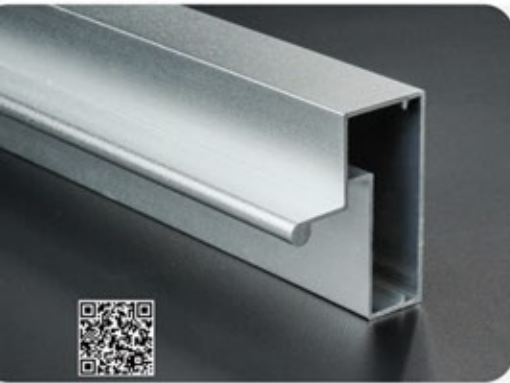
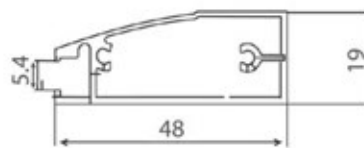

FHD-45

- Anodize
- Silver Pasir

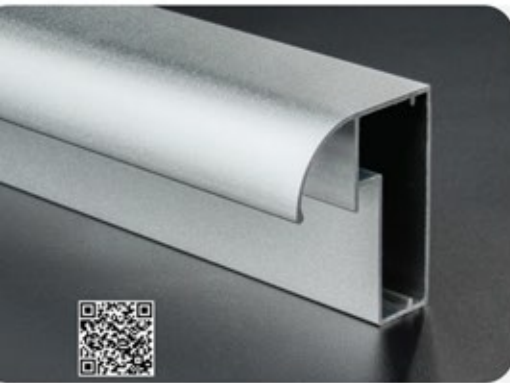
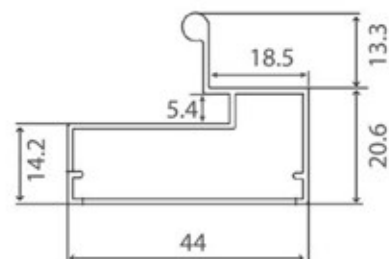

FHD-46

- Anodize
- Brush

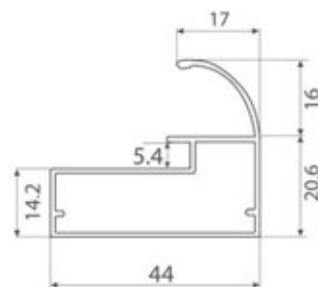

FHD-127

- Anodize
- Brush
- Silver Pasir
- SS
- Hitam
- Mirror
- Gold Mirror

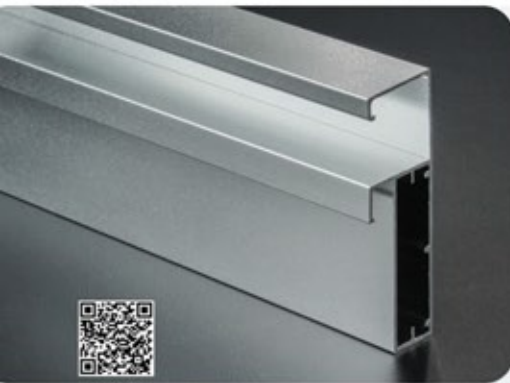
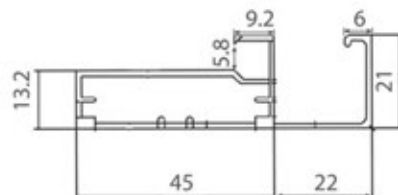

LENAGA LEFHD-127

- Anodize
- Mirror
- Silver Pasir
- Hitam
- SS
- Gold Mirror

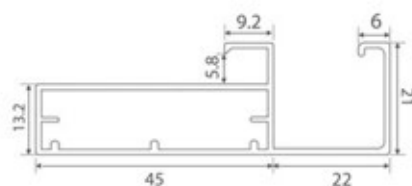

• Panjang 3 Meter

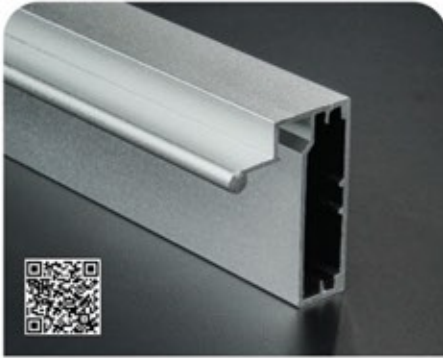

FHD-128

- Anodize ● Hitam
- Brush ● Mirror
- Silver Pasir ● Gold Mirror
- SS

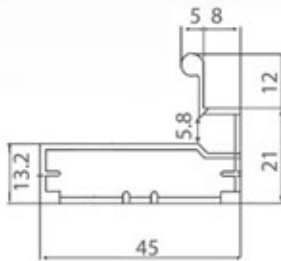

LENAGA LEFHD-128

- Anodize ● Hitam
- Silver Pasir ● Mirror
- SS ● Gold Mirror

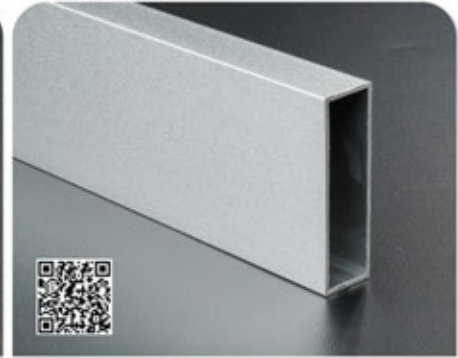
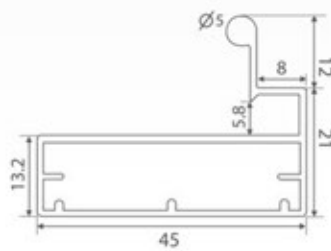

FB-47

- Anodize
- Silver Pasir

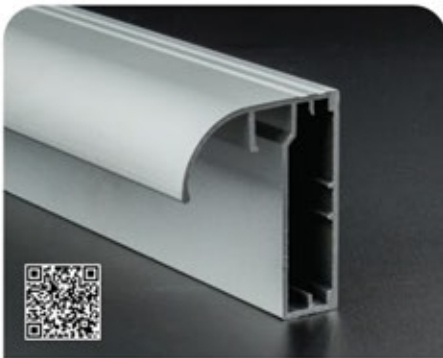
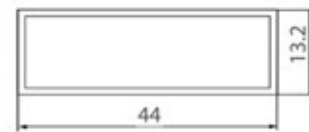

FHD-129

- Anodize

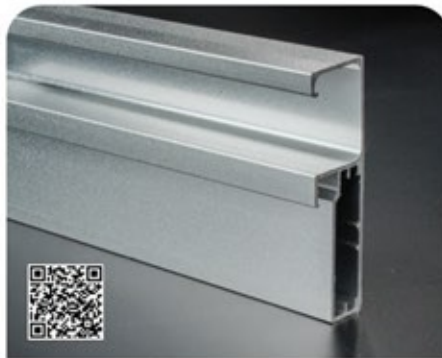
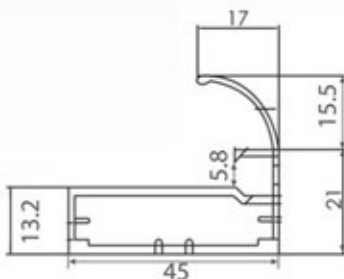

FHD-130

- Brush
- Mirror

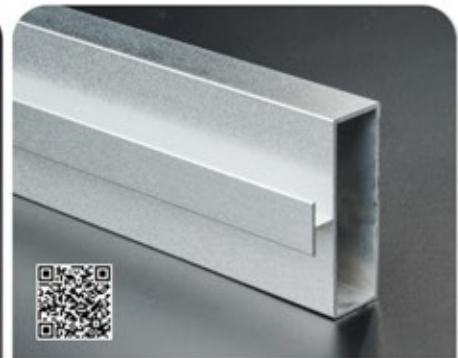
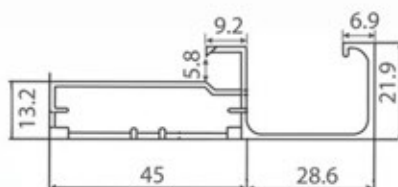

FT-45

- Anodize
- Brush
- Silver Pasir
- SS

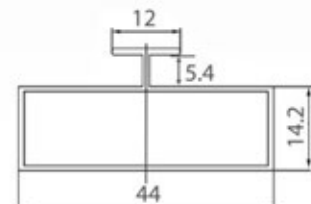

• Panjang 3 Meter

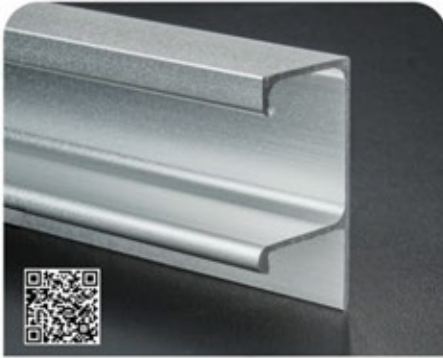

HUBEN / LENAGA
GP-30 / LEGP-30

- Anodize
- Brush
- Silver Pasir
- SS
- Hitam
- Mirror
- Gold Mirror

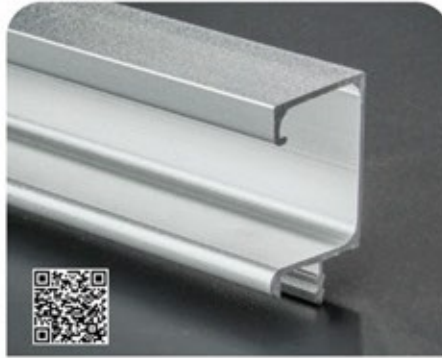
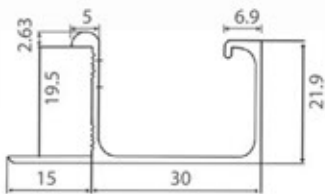

GP-32

- Anodize
- Brush
- Mirror
- Silver Pasir
- SS
- Hitam

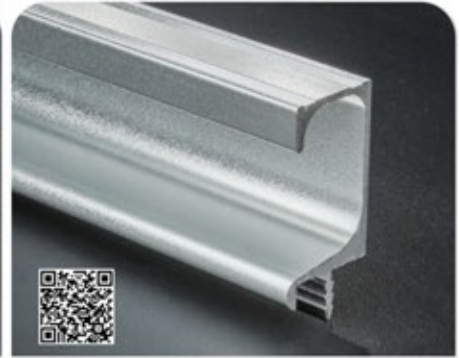
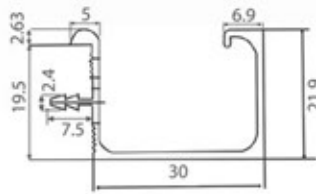

GP-35

- Anodize
- Brush
- Mirror
- Silver Pasir
- SS
- Hitam

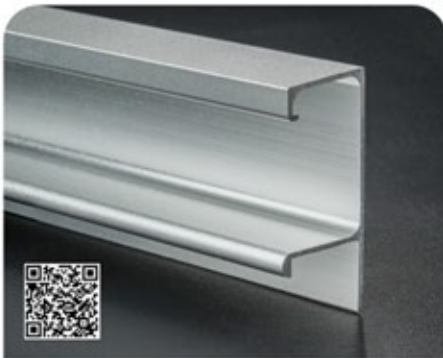
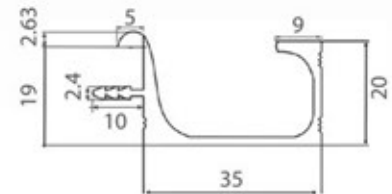

GP-36

- Brush
- Mirror
- Silver Pasir
- SS
- Hitam

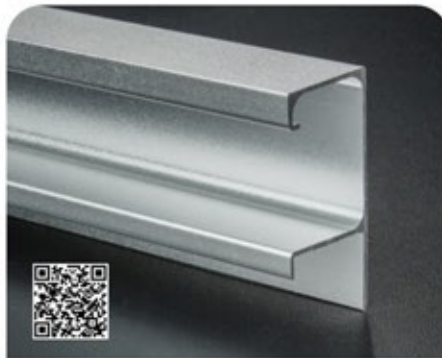
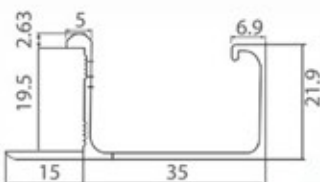

HUBEN / LENAGA
GP-37 / LEGP-37

- Anodize
- Silver Pasir
- SS
- Hitam
- Mirror
- Gold Mirror

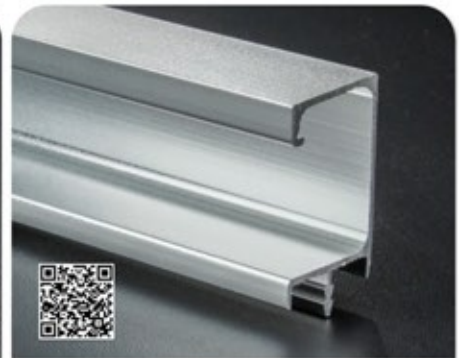
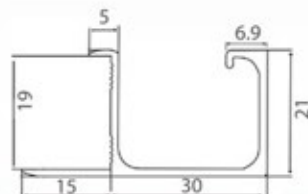

GP-38

- Anodize
- Brush
- Mirror
- Silver Pasir
- SS
- Hitam

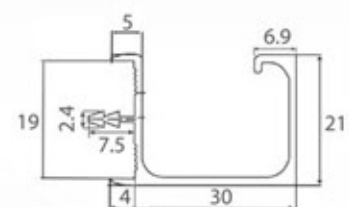

• Panjang 3 Meter

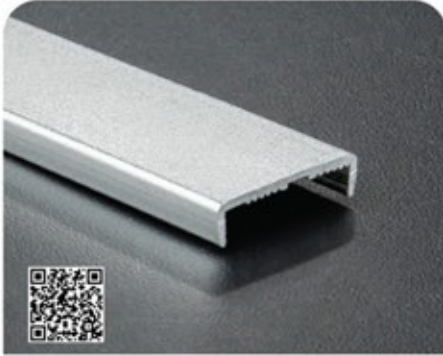

HUBEN / LENAGA
EA-17 / LEA-17

- Anodize ● Hitam
- Brush ● Mirror
- Silver Pasir ● Gold Mirror
- SS

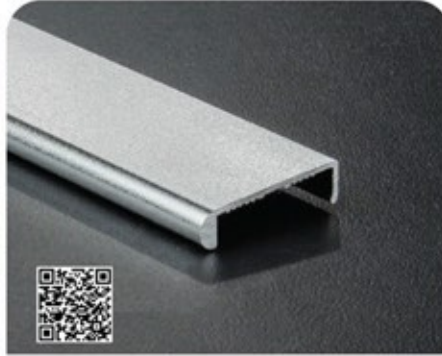
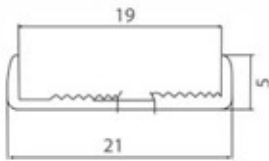

HUBEN / LENAGA
EA-19 / LEA-19

- Anodize ● Hitam
- Brush ● Mirror
- Silver Pasir ● Gold Mirror
- SS

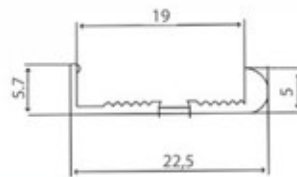

EA-92

- Brush
- SS

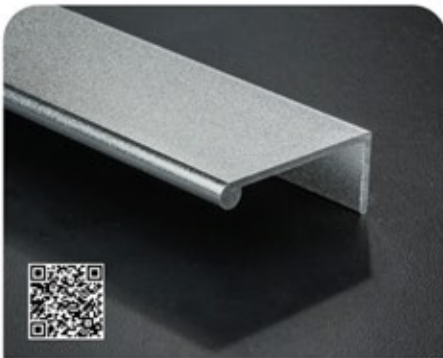
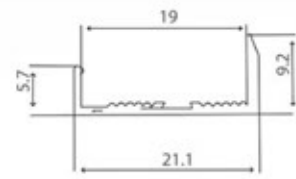

LP-375

- Anodize ● Hitam
- Brush ● Mirror
- Silver Pasir ● Gold Mirror
- SS

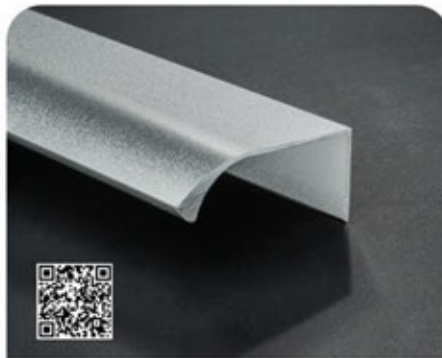

LP-376

- Anodize ● Hitam
- Silver Pasir ● Mirror
- SS
- Gold Mirror

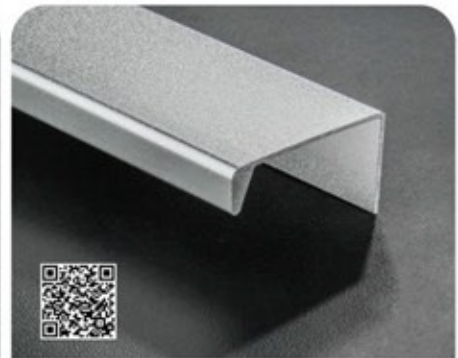
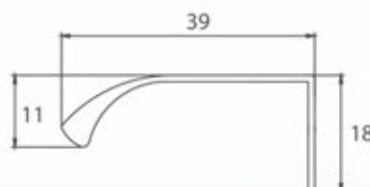

LP-377

- Anodize ● Hitam
- Silver Pasir ● Mirror
- SS
- Gold Mirror

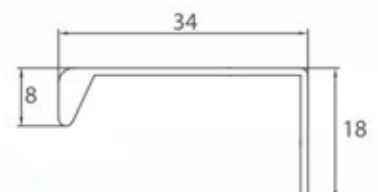

• Panjang 3 Meter

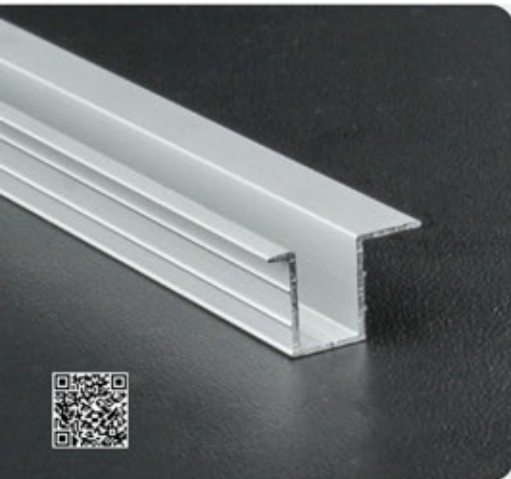

HUBEN / LENAGA AS-75 / LAS-75

- Anodize
- Bronze

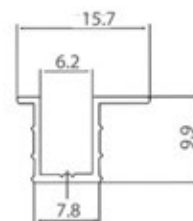
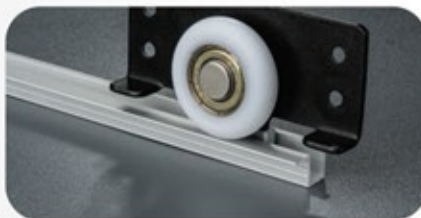

Pasangan Roda :
SD-75, SD-753

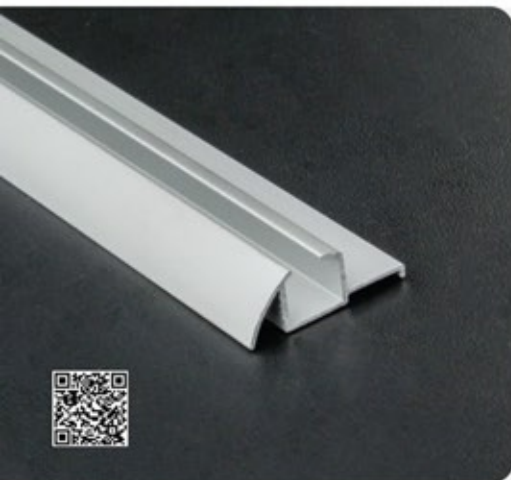

HUBEN / LENAGA AS-380 / LAS-380

- Anodize
- Bronze

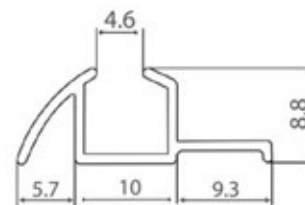

Pasangan Roda :
SD-380

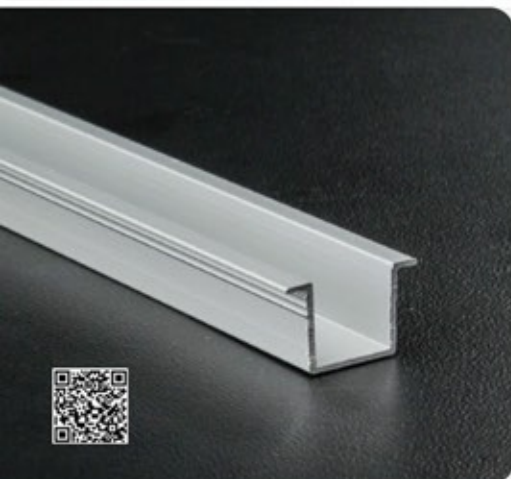

HUBEN / LENAGA SD-02-U / LAS-02-U (Rel Atas)

- Anodize
- Bronze

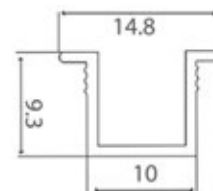

Pasangan Roda :
SD-12, SD-338, SD-3141



HUBEN / LENAGA SD-02-M / LAS-02-M (Rel Bawah)

- Anodize
- Bronze

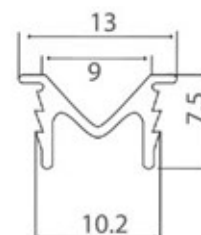

Pasangan Roda :
SD-12, SD-338, SD-3141

• Panjang 2 & 3 Meter



AS-99-A (Rel Atas)

● Anodize

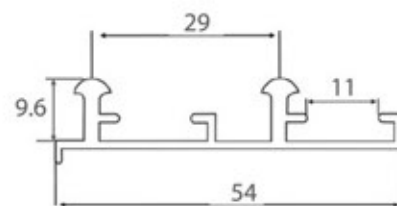

Pasangan Roda :
RG-99, RG-100

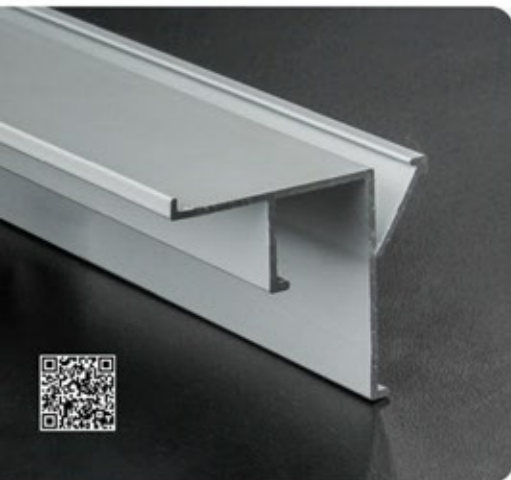

AS-99-B (Rel Bawah)

● Anodize

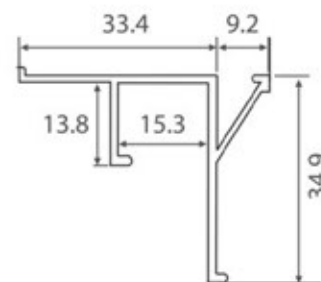

Pasangan Roda :
RG-99, RG-100

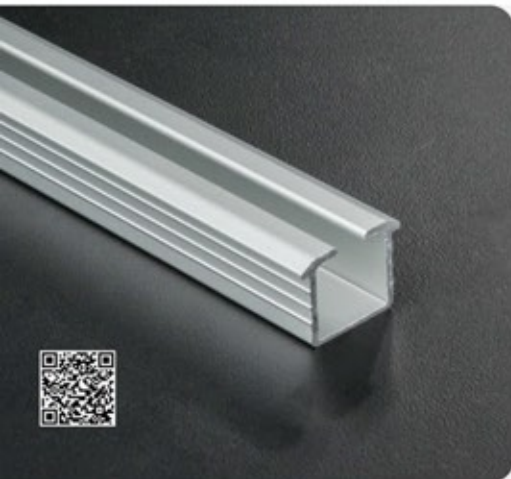

AS-452-A (Rel Atas)

● Anodize

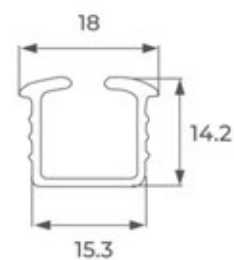

Pasangan Roda :
SD-452, SD-453



AS-452-B (Rel Bawah)

● Anodize

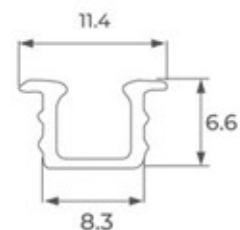

Pasangan Roda :
SD-452, SD-453

HUBEN

REL LACI



FE-30

REL FULL EXTENSION

Material	: Cold Rolled Steel
Finish	: Zinc Plated
Ukuran	: 250 - 500 mm
Minimal Kedalaman Kabinet	: Ukuran rel + min. 5 mm
Lebar	: 30 mm
Kapasitas Beban	: 20 kg
Siklus Pemakaian	: 50.000 Kali

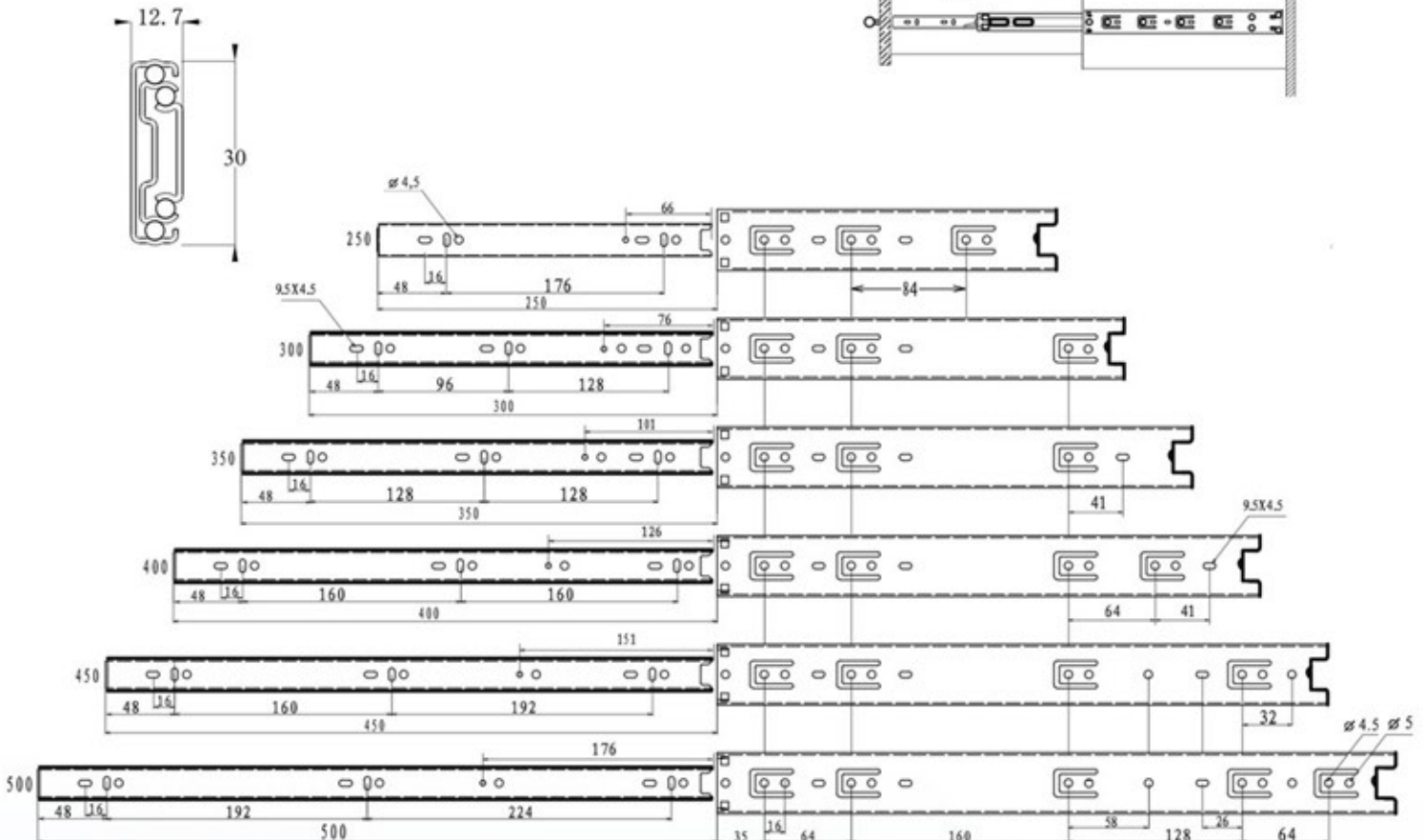
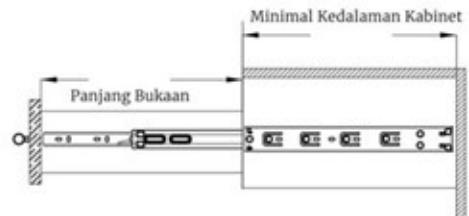
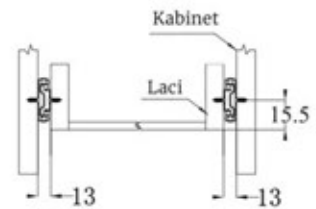

LENAGA



RD-35 REL FULL EXTENSION

Material	: Cold Rolled Steel
Finish	: Zinc Plated (Hitam)
Ukuran	: 250 - 500 mm
Minimal Kedalaman Kabinet	: Ukuran rel + min. 5 mm
Lebar	: 35 mm
Kapasitas Beban	: 25 kg
Siklus Pemakaian	: 50.000 Kali

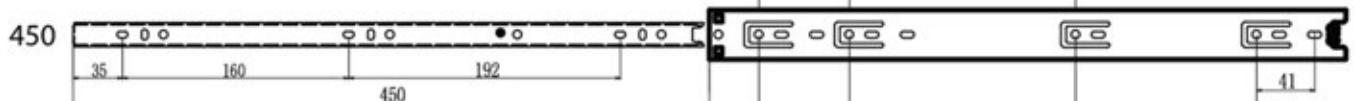
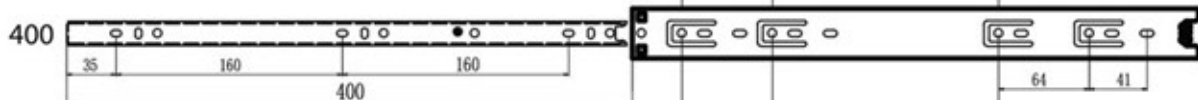
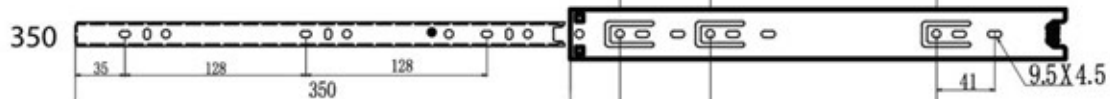
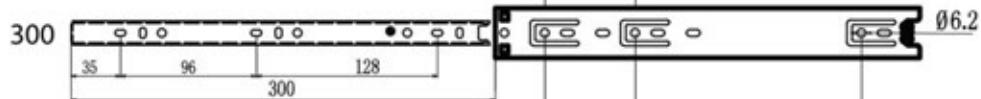
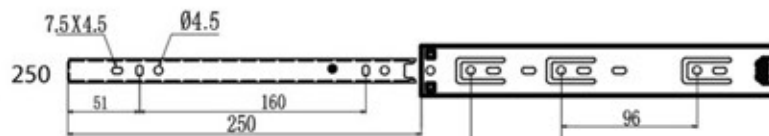
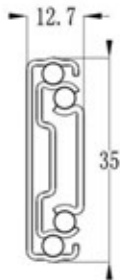
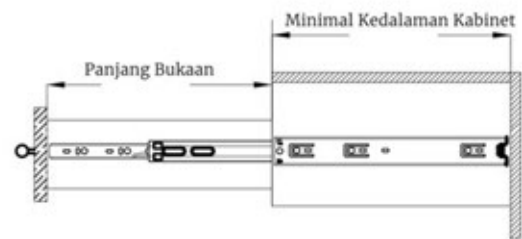
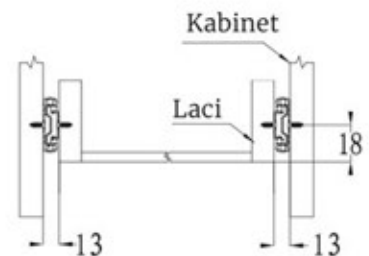



BM-35 REL SLOW MOTION FULL EXTENSION

Material	: Cold Rolled Steel
Finish	: Zinc Plated (Hitam)
Ukuran	: 250 - 500 mm
Minimal Kedalaman Kabinet	: Ukuran rel + min. 5 mm
Lebar	: 35 mm
Kapasitas Beban	: 25 kg
Siklus Pemakaian	: 50.000 Kali

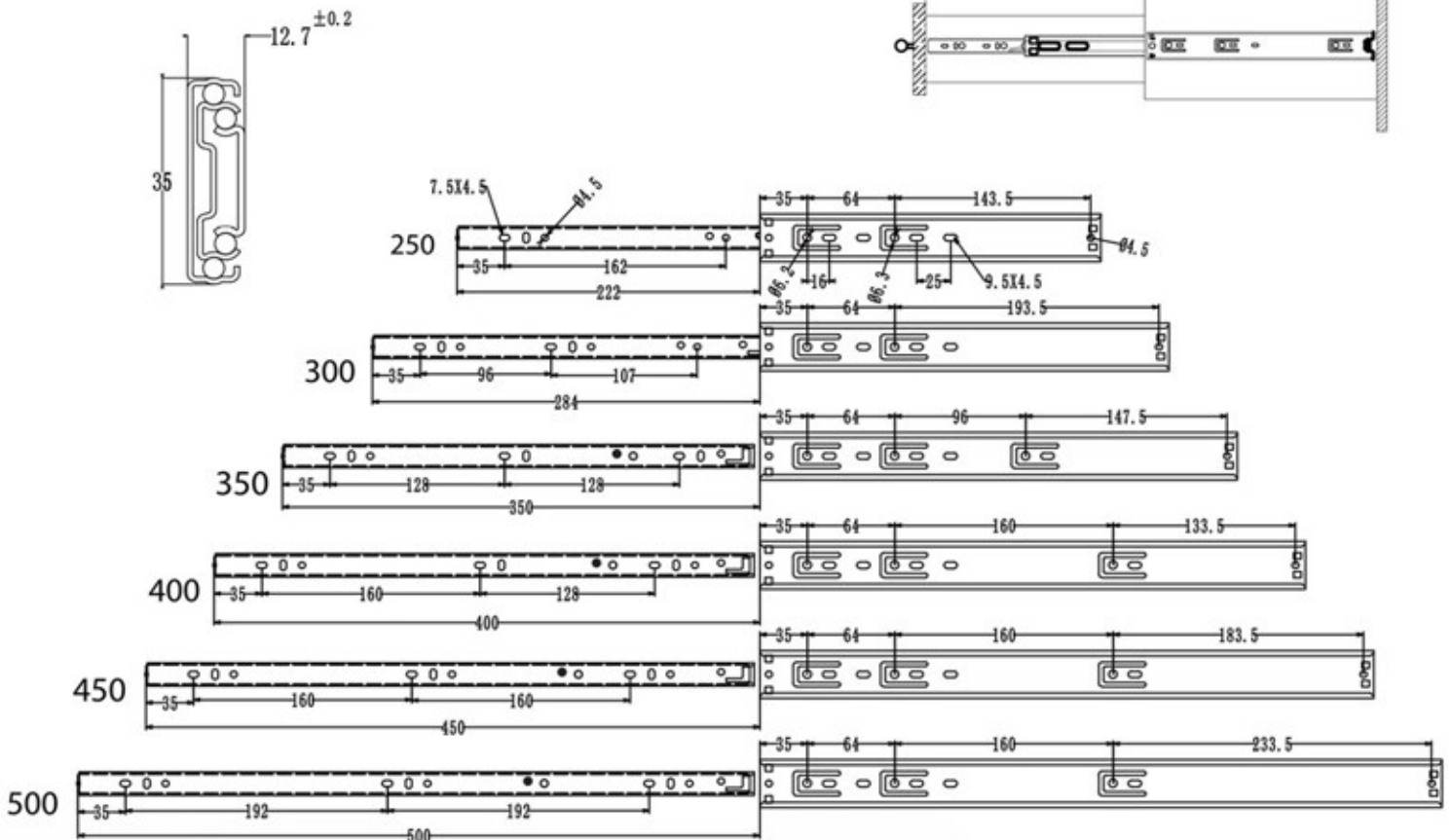
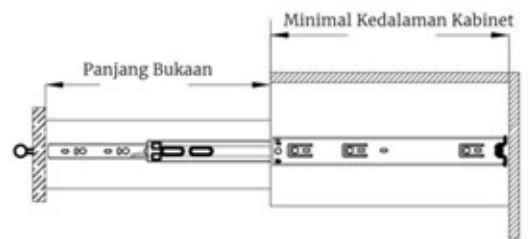
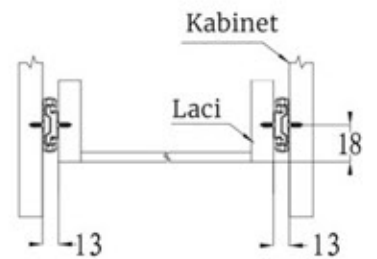



FE-37 REL FULL EXTENSION

- | | |
|---------------------------|--------------------------|
| Material | : Cold Rolled Steel |
| Finish | : Zinc Plated (Hitam) |
| Ukuran | : 250 - 600 mm |
| Minimal Kedalaman Kabinet | : Ukuran rel + min. 5 mm |
| Lebar | : 37 mm |
| Kapasitas Beban | : 30 kg |
| Siklus Pemakaian | : 50.000 Kali |

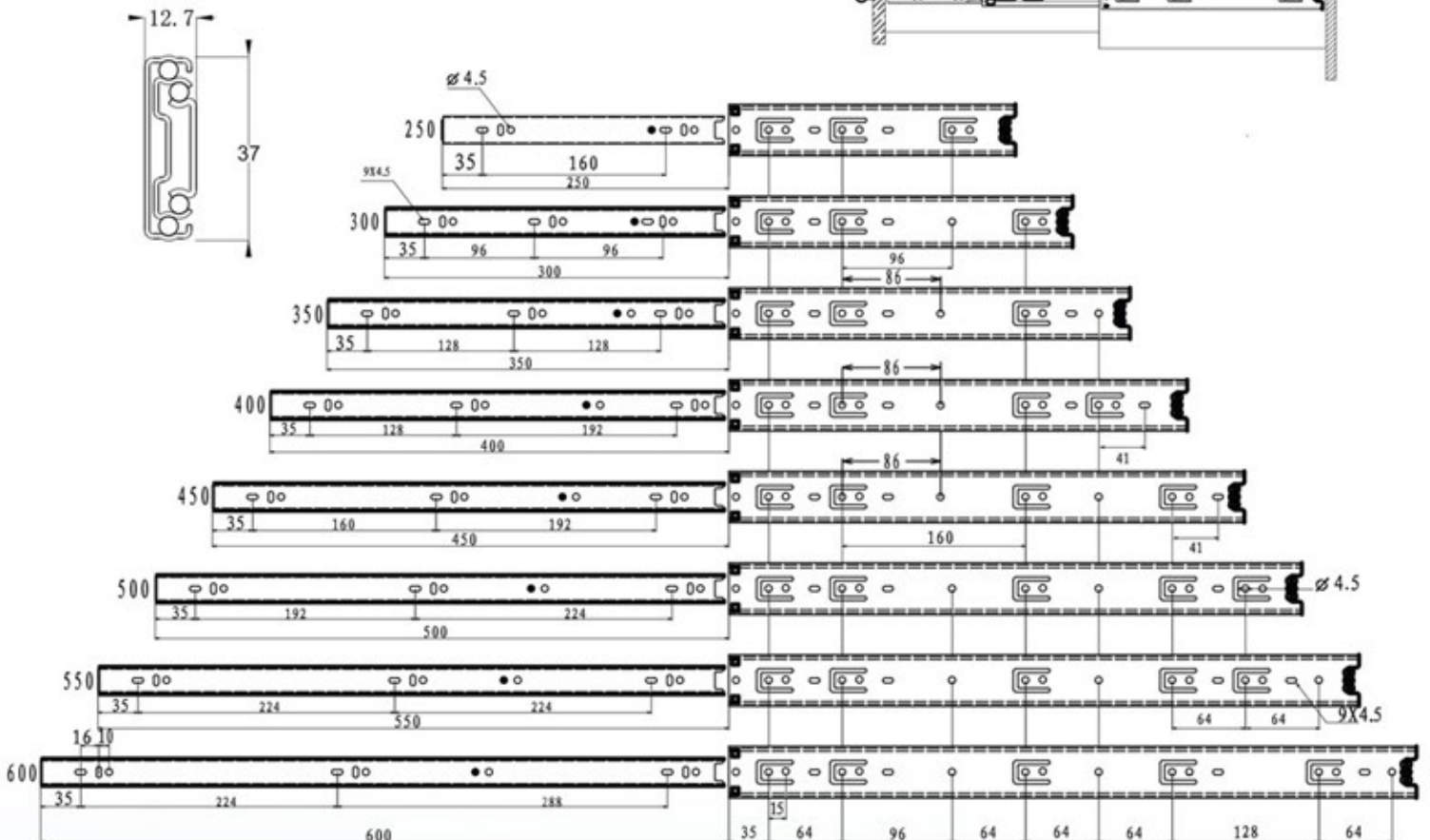
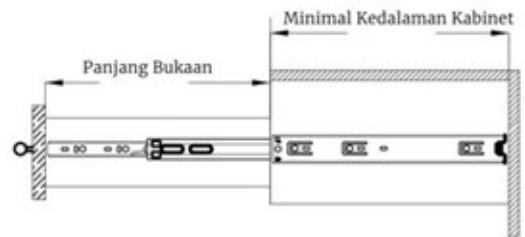
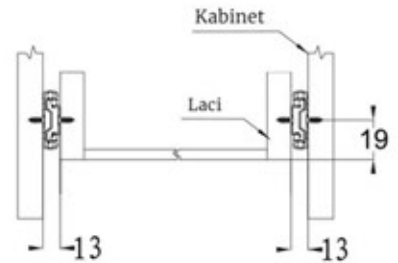



RD-45 REL FULL EXTENSION

Material	: Cold Rolled Steel
Finish	: Zinc Plated (Hitam)
Ukuran	: 250 - 500 mm
Minimal Kedalaman Kabinet	: Ukuran rel + min. 5 mm
Lebar	: 45 mm
Kapasitas Beban	: 30 kg
Siklus Pemakaian	: 50.000 Kali

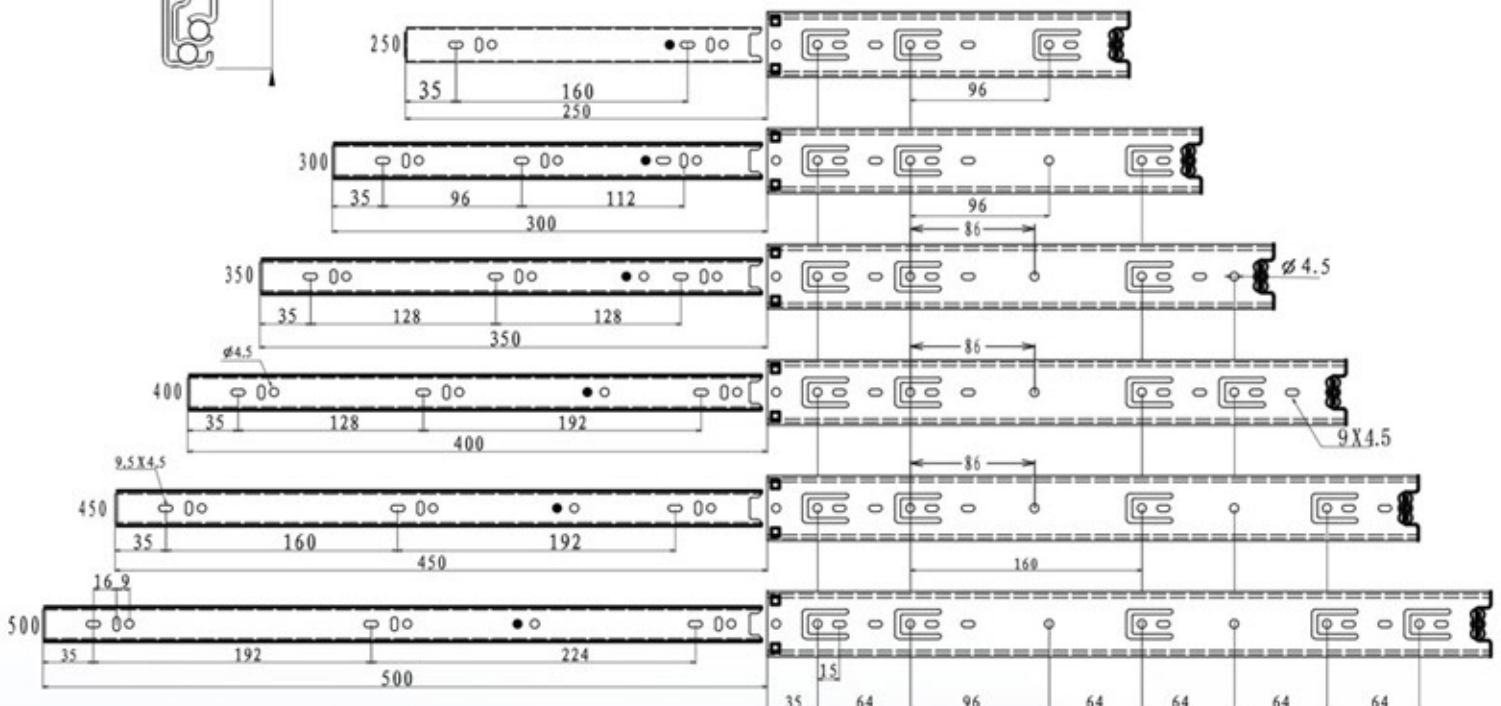
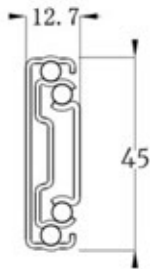
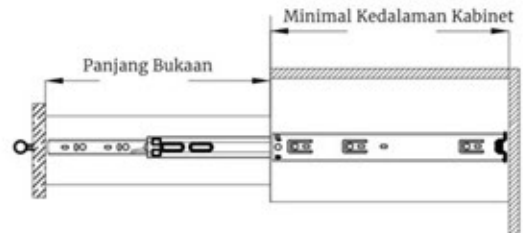
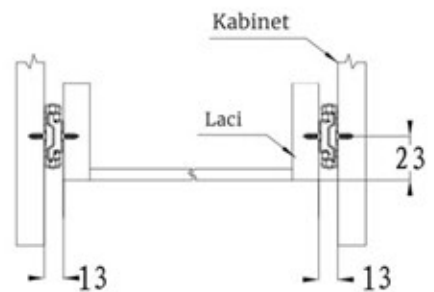



FE-45 REL FULL EXTENSION

Material : Cold Rolled Steel
Finish : Zinc Plated (Hitam)
Ukuran : 250 - 600 mm
Minimal Kedalaman Kabinet : Ukuran rel + min. 5 mm
Lebar : 45 mm
Kapasitas Beban : 35 kg
Siklus Pemakaian : 50.000 Kali

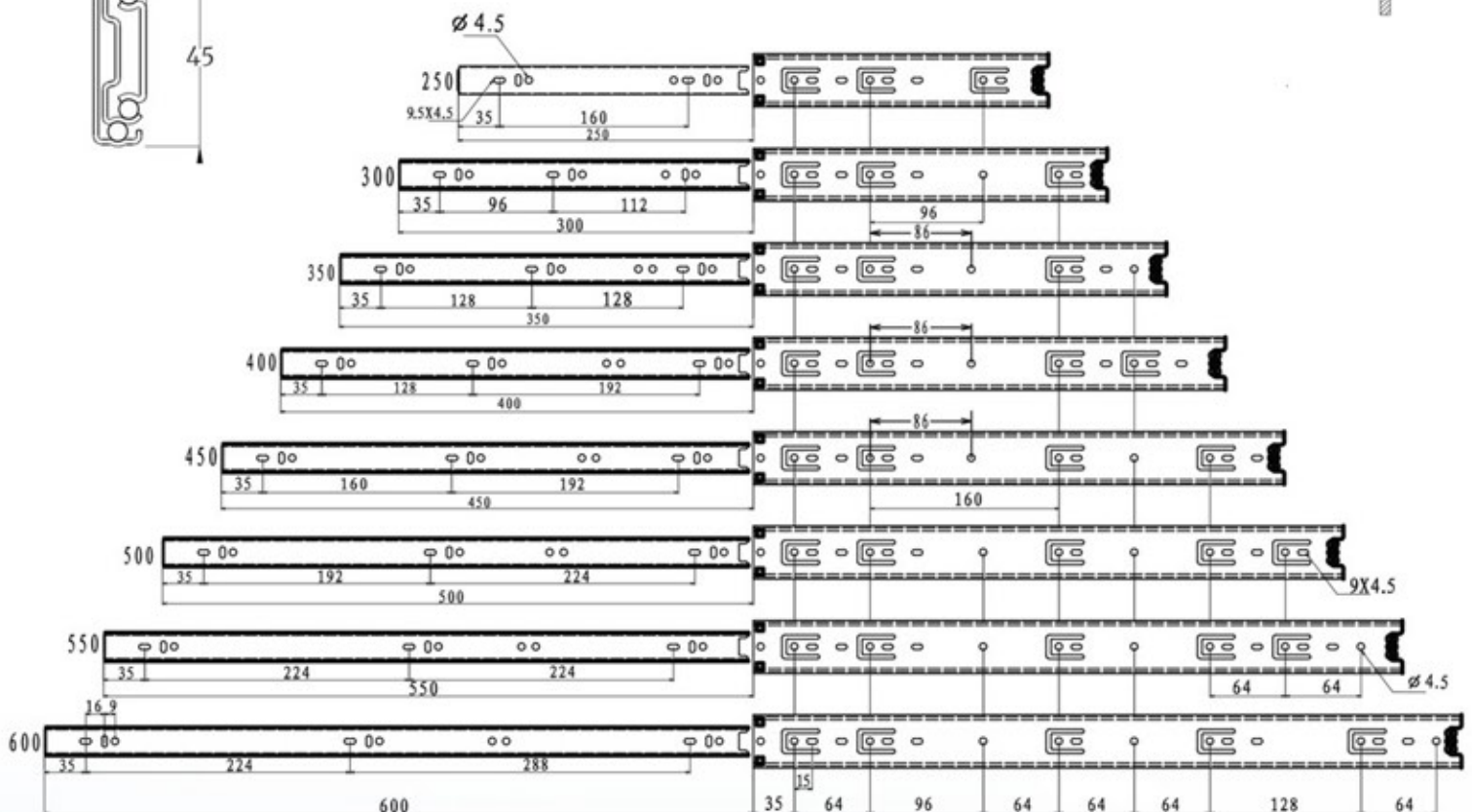
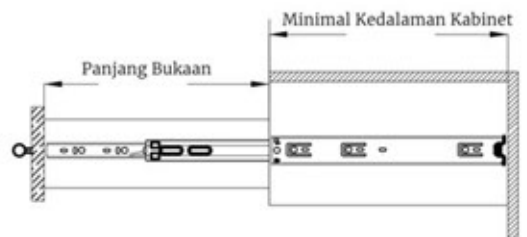
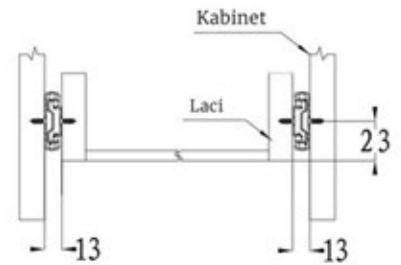



BM-45 REL SLOW MOTION FULL EXTENSION

Material	: Cold Rolled Steel
Finish	: Zinc Plated (Hitam)
Ukuran	: 250 - 600 mm
Minimal Kedalaman Kabinet	: Ukuran rel + min. 5 mm
Lebar	: 45 mm
Kapasitas Beban	: 30 kg
Siklus Pemakaian	: 50.000 Kali

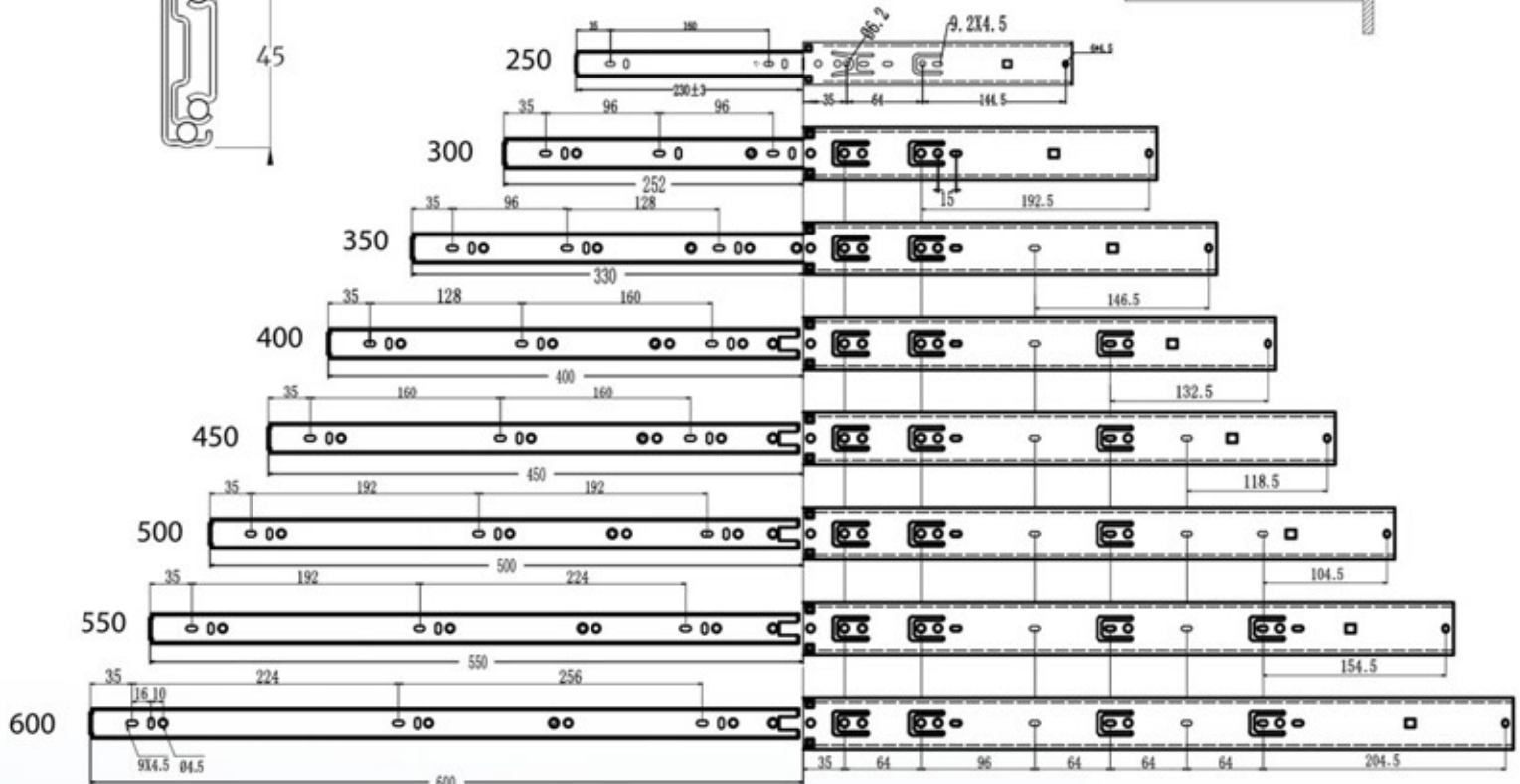
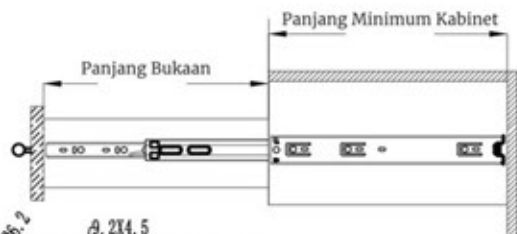
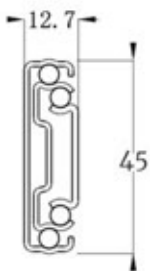
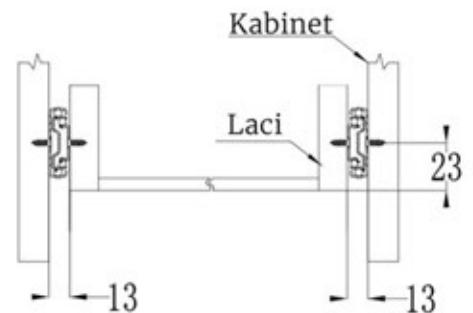



MS-17 REL MINI SLIDE 17 mm

Material	: Cold Rolled Steel
Finish	: Zinc Plated
Ukuran	: 246, 310, 374 mm
Kapasitas Beban	: 10 kg
Siklus Pemakaian	: 50.000 Kali

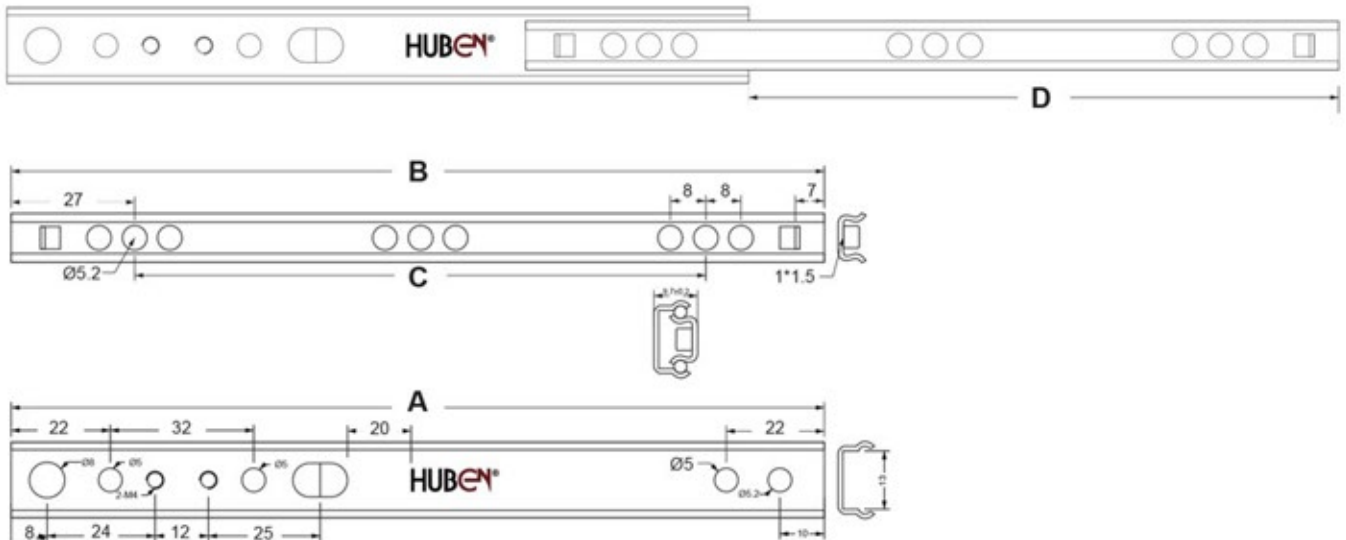

Ukuran	A	B	C	D
246	246	246	192	171
310	310	310	256	225
374	374	374	320	275



RLH / RLE REL LACI RODA

Material	: Cold Rolled Steel
Finish	: Beige
Ukuran	: 250 - 600 mm
Kapasitas Beban	: 20 kg
Siklus Pemakaian	: 50.000 Kali

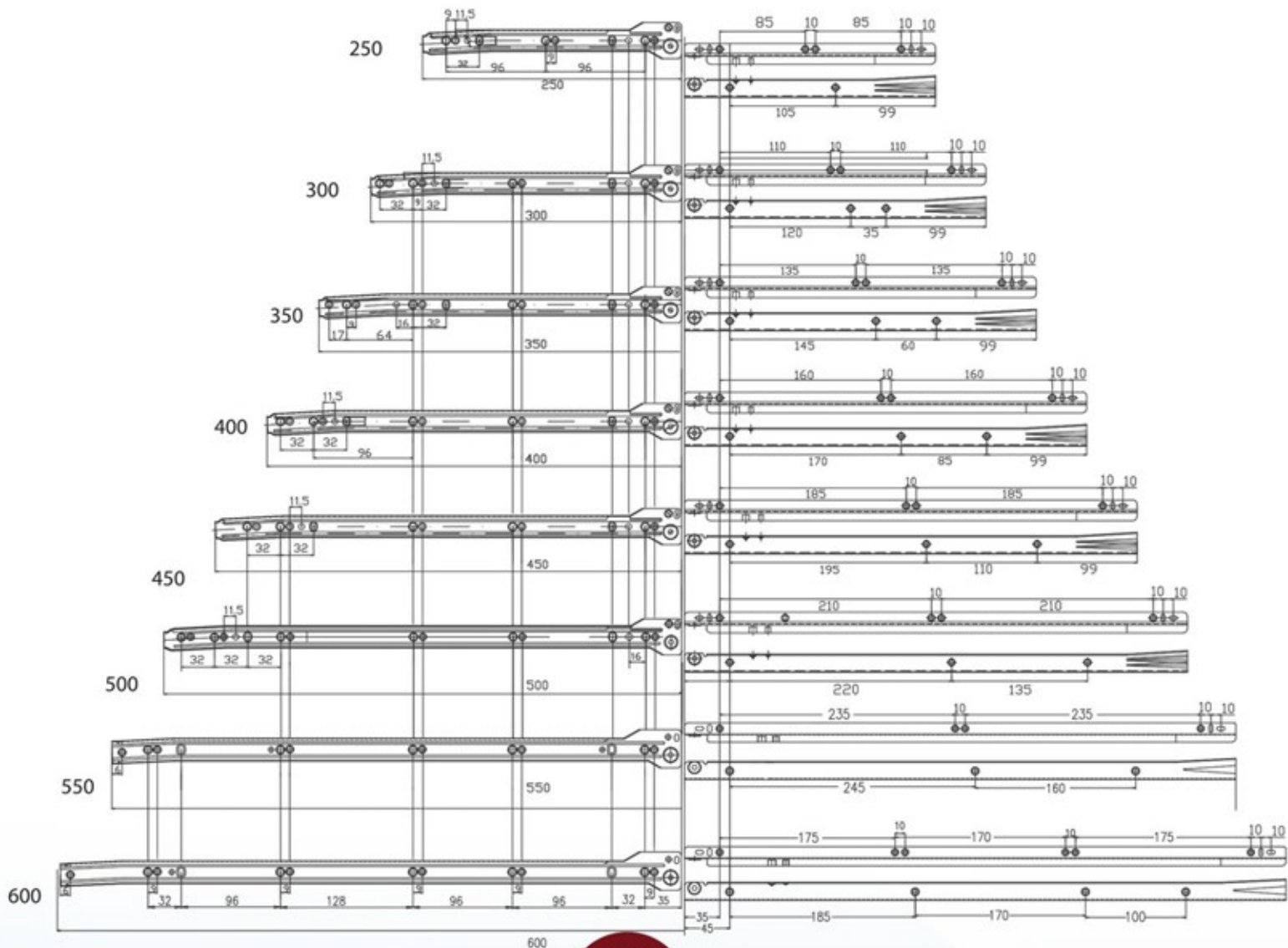

TN-36-PIN REL TANEM PIN SLOW-MOTION FULL EXTENSION



Material : Cold Rolled Steel
 Finish : Zinc Plated
 Ukuran : 250 - 600 mm
 Kapasitas Beban : 30 kg
 Siklus Pemakaian : 80.000 Kali

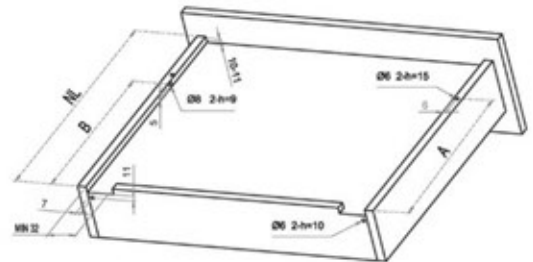
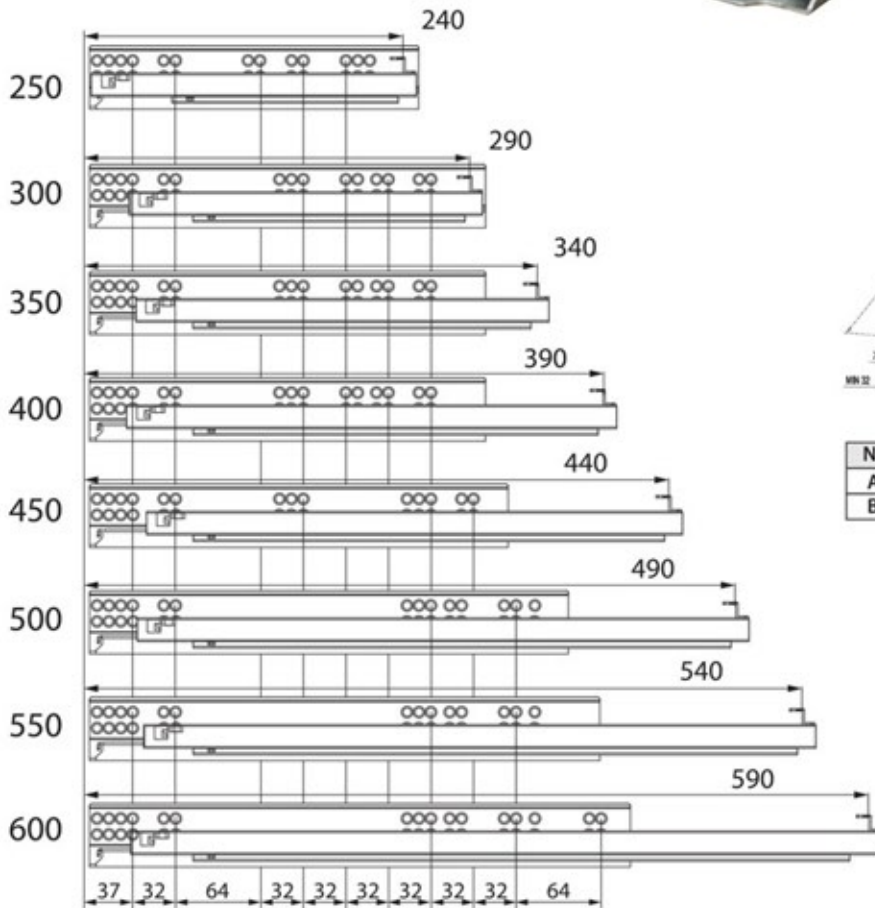

NL	250	300	350	400	450	500	550	600
A	190	245	270	305	330	355	390	415
B	200.5	255.5	280.5	319.5	369.5	419.5	469.5	519.5



Scan untuk video pemasangan

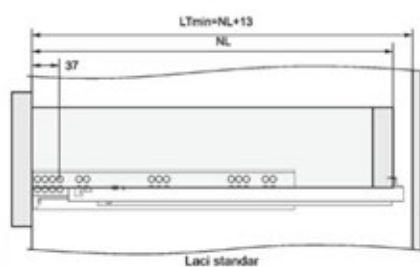
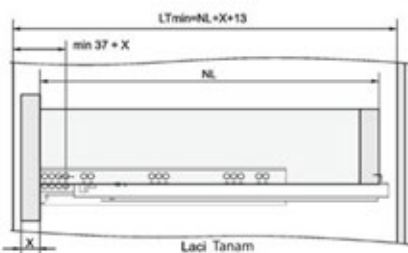

LT - Kedalaman bagian dalam kabinet
 NL - Nominal panjang rel
 X - Tebal Maksimum Papan ≤ 16 mm



TN-37-KO

REL TANEM KLIP-ON SLOW-MOTION FULL EXTENSION

Material	: Cold Rolled Steel
Finish	: Zinc Plated
Ukuran	: 250 - 600 mm
Kapasitas Beban	: 30 kg
Siklus Pemakaian	: 80.000 Kali

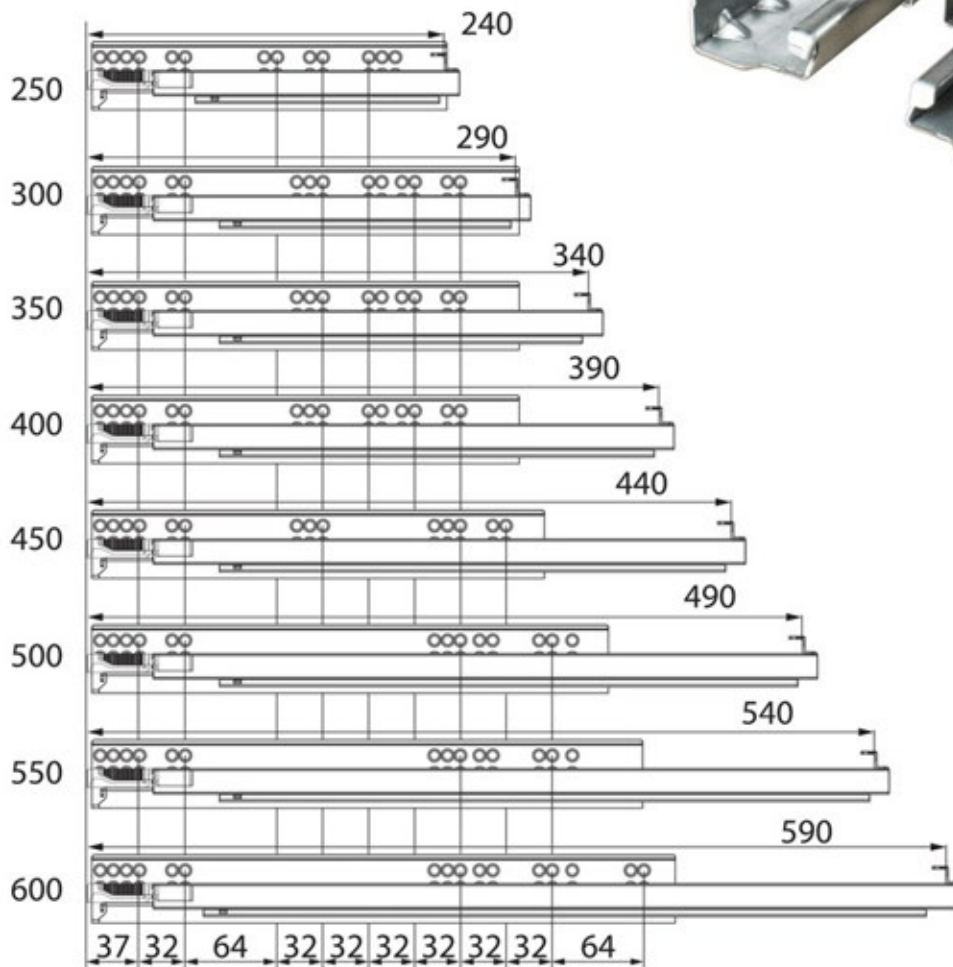

Scan untuk video pemasangan

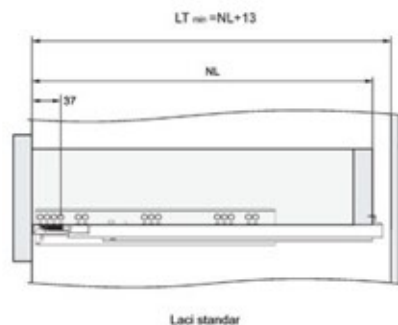
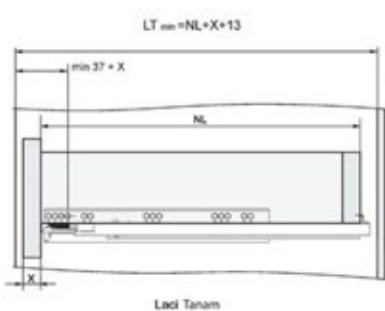

LT - Kedalaman bagian dalam kabinet
 NL - Nominal panjang rel
 X - Tebal Maksimum ≤ 16 mm

TN-38-PO REL TANEM PUSH OPEN KLIP-ON FULL EXTENSION

Material : Cold Rolled Steel
 Finish : Zinc Plated
 Ukuran : 250 - 500 mm
 Kapasitas Beban : 30 kg
 Siklus Pemakaian : 80.000 Kali

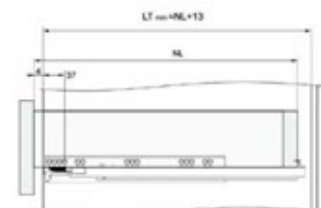
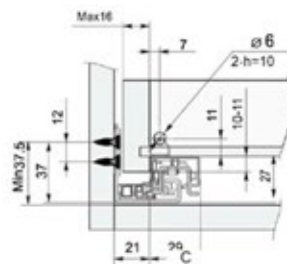
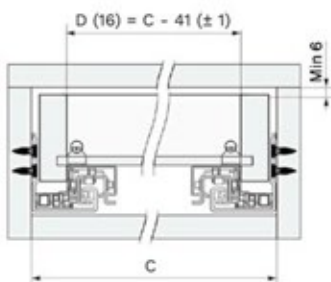
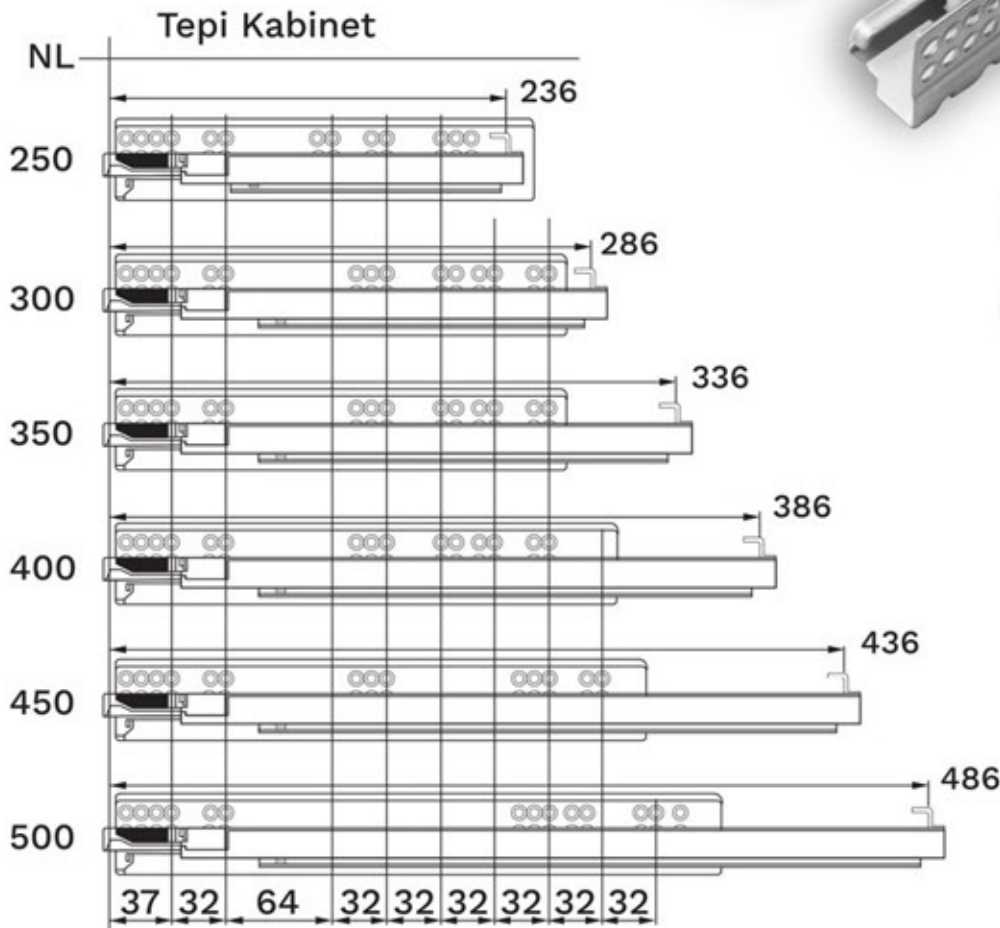

Laci Standard

- A - Kedalaman bagian dalam kabinet
- B - Nominal Panjang Rel

- C - Lebar bagian dalam kabinet
- D - Lebar bagian dalam Laci ($\leq 16\text{mm}$)

RODA GANTUNG RG-99 (2 Pintu) & RG-100 (3 Pintu)



Petunjuk pemasangan untuk 2 daun pintu

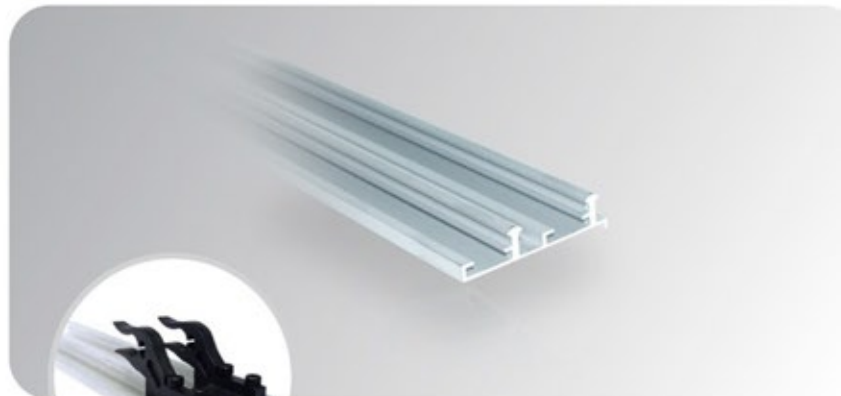
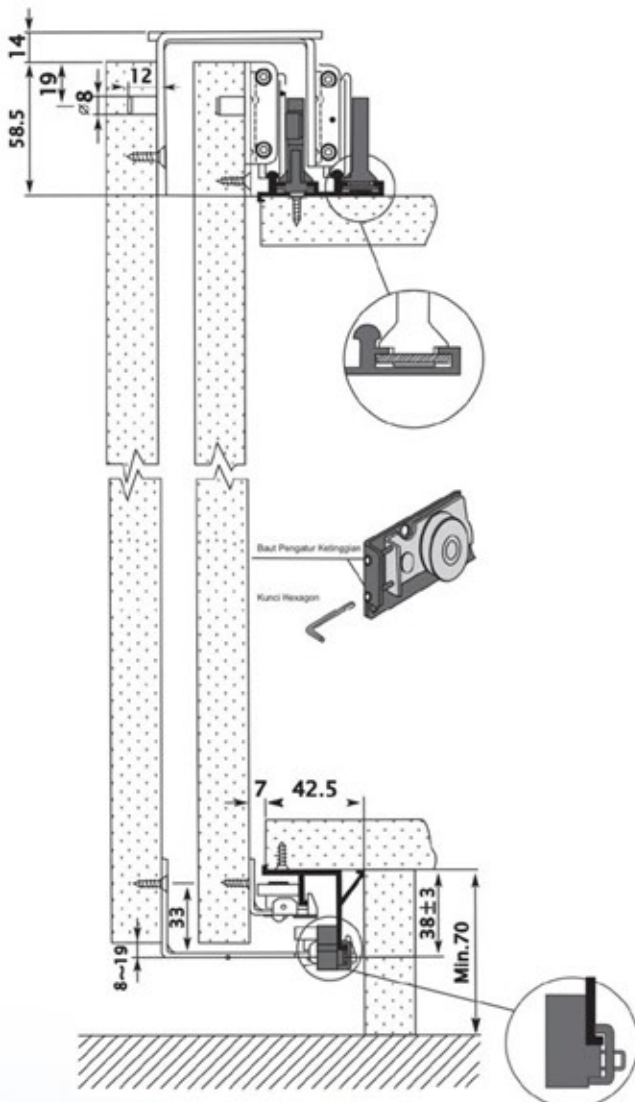

AS-99-A (Rel Atas)
Warna : Anodize
Panjang : 2 & 3 m

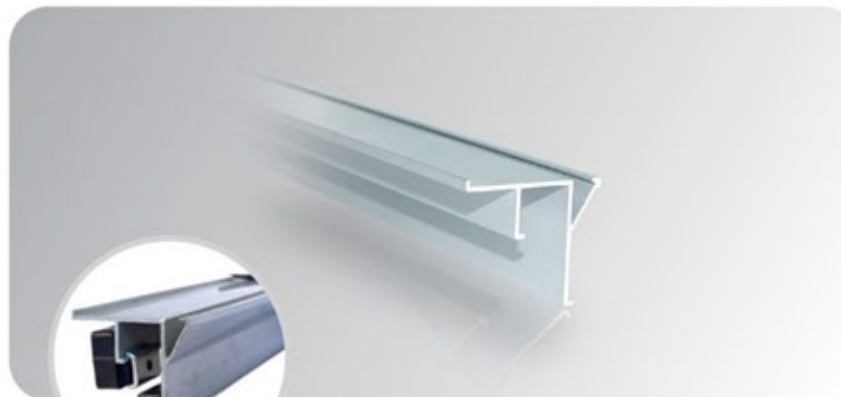
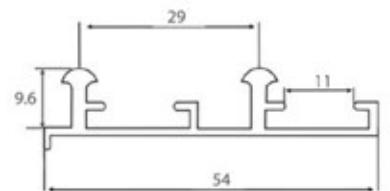

AS-99-B (Rel Bawah)
Warna : Anodize
Panjang : 2 & 3 m

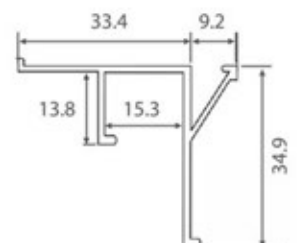



RG-99



RG-100



Roda Atas
Bagian Luar

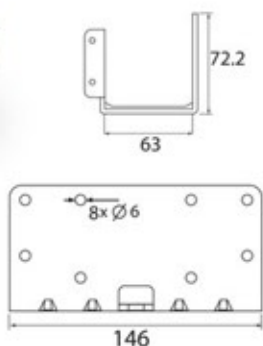

Roda Bawah
Bagian Luar

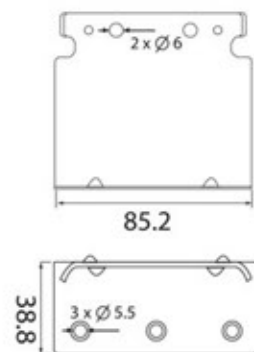

RG-99 (2 pintu) : 1 Set Kiri dan Kanan
RG-100 (3 pintu) : 1 Set Kiri dan Kanan

RG-99 (2 pintu) : 1 Set Kiri dan Kanan
RG-100 (3 pintu) : 1 Set Kiri dan Kanan



Roda Atas
Bagian Dalam

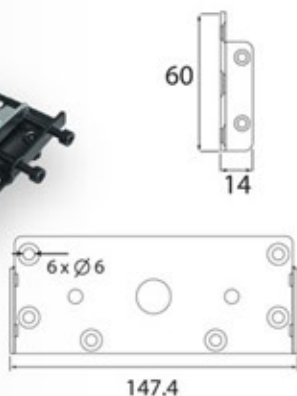

Roda Bawah
Bagian Dalam

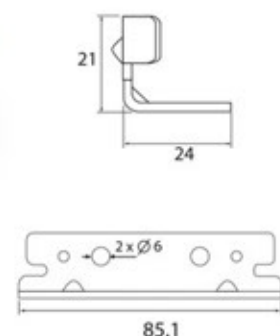

RG-99 (2 pintu) : 1 Set Kiri dan Kanan
RG-100 (3 pintu) : 2 Set Kiri dan Kanan

RG-99 (2 pintu) : 1 Set Kiri dan Kanan
RG-100 (3 pintu) : 2 Set Kiri dan Kanan



Stopper Bagian Atas

4 Pcs



Stopper Bagian Bawah

4 Pcs



Kunci Allen

4 mm - 1pc
3 mm - 1pc



DAMPER-99

Damper **Slow-Mo** untuk
Roda Gantung



1 Set Kiri dan Kanan

RODA PINTU SLIDING SLOW MOTION SD-452 & SD-453



SD-452



SD-453

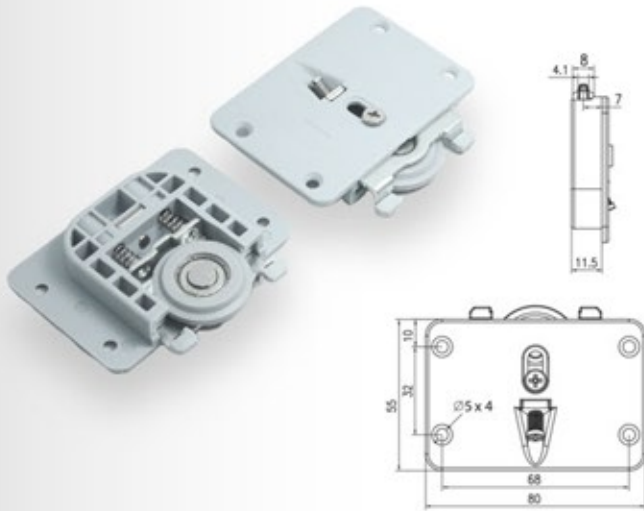

SD-452 (2 Pintu) Roda Atas (Plastik) : 4 Pcs
SD-453 (3 Pintu) Roda Atas (Plastik) : 6 Pcs



SD-452 (2 Pintu) Roda Bawah (Plat Besi) : 4 Pcs
SD-453 (3 Pintu) Roda Bawah (Plat Besi) : 6 Pcs

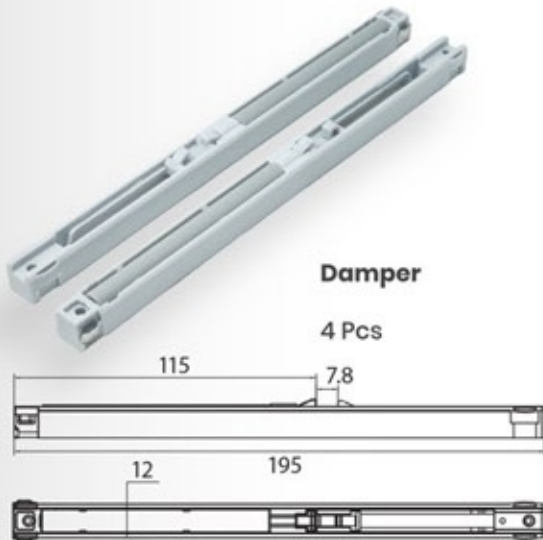

Damper

4 Pcs



Kunci Allen

Kunci Allen 2 mm : 1pc



Skrup

Skrup Tapping Plus 4x16

SD-452 (2 Pintu) : 32 Pcs
SD-453 (3 Pintu) : 48 Pcs

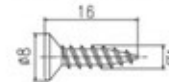

AS-452 - A (Rel Atas)

Warna : Anodize
 Panjang : 2 & 3 m
 Rel Aluminium Bagian Atas
 Untuk Roda SD-452 & SD-453

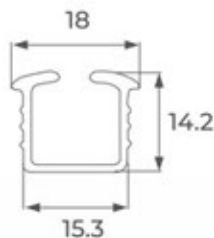

AS-452- B (Rel Bawah)

Warna : Anodize
 Panjang : 2 & 3 m
 Rel Aluminium Bagian Bawah
 Untuk Roda SD-452 & SD-453

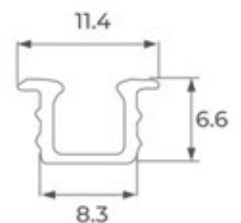

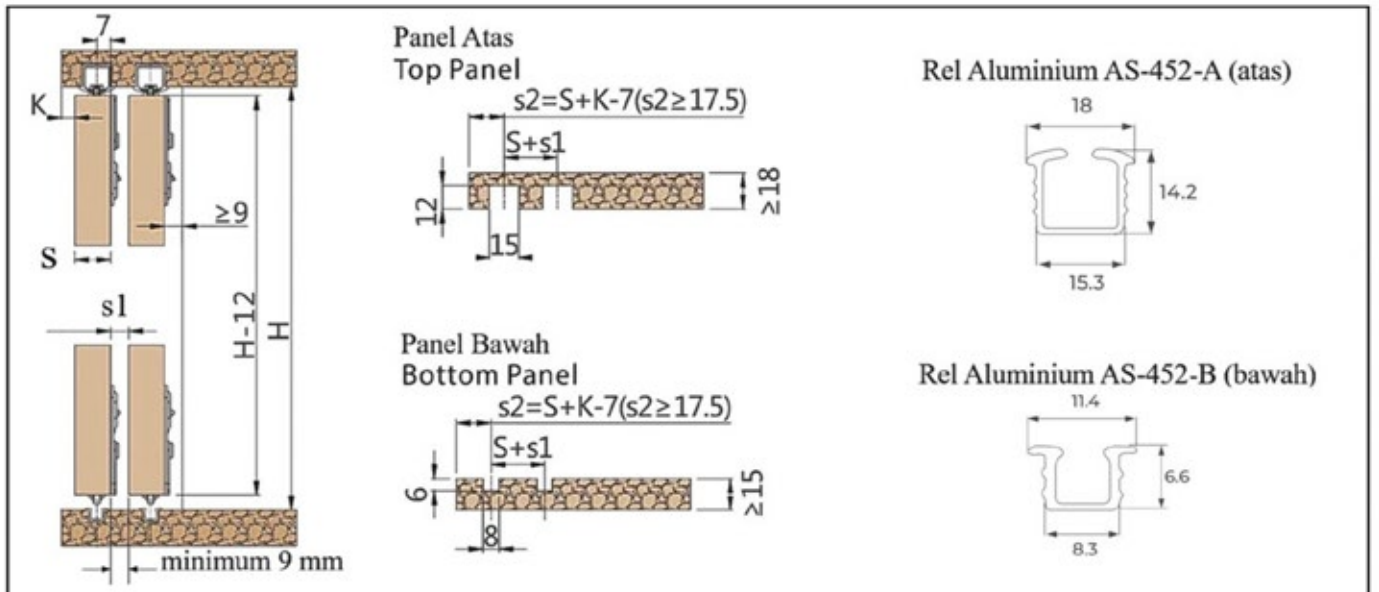

Masukan kedua damper ke dalam rel aluminium

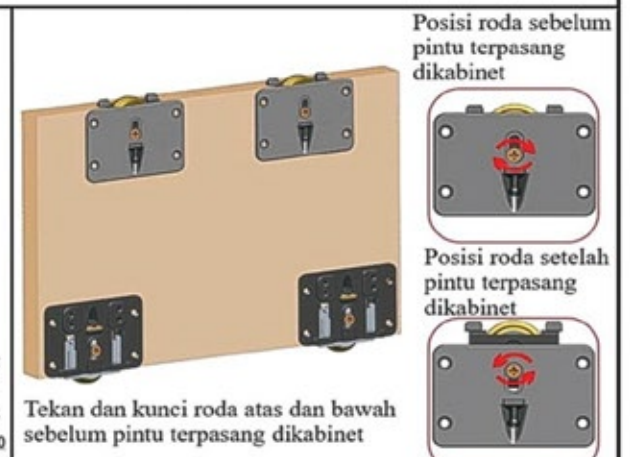
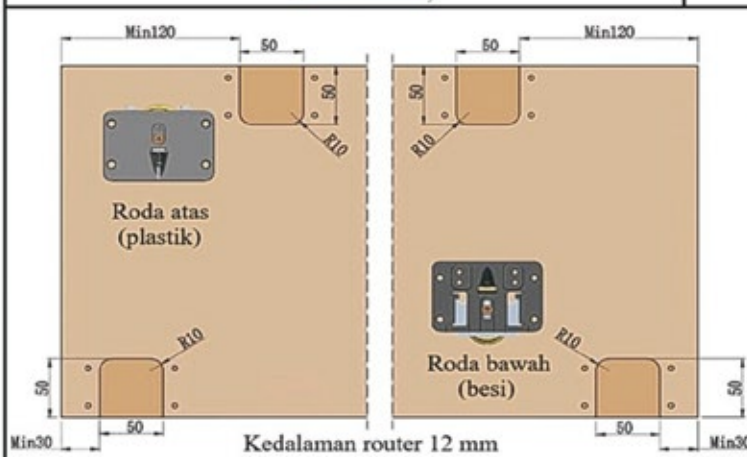
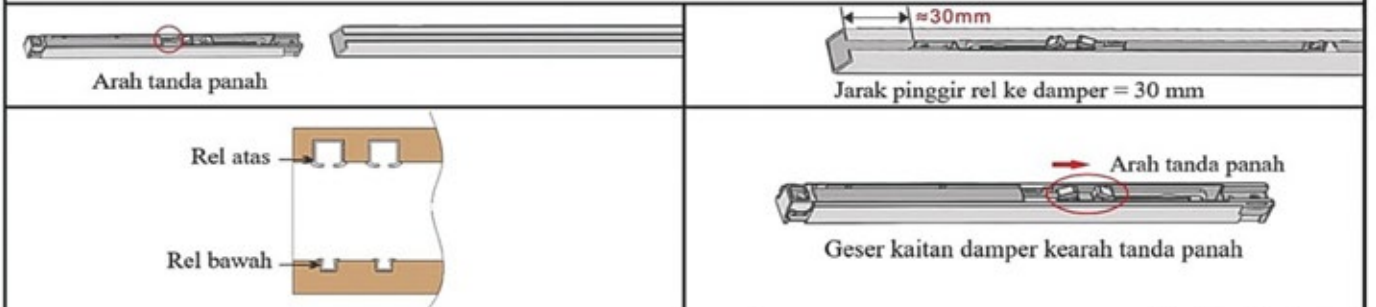

Geser pintu sampai pinggir dan posisikan damper

Sesuaikan jarak menggunakan baut seperti digambar

Kencangkan dan kunci damper

Aksesoris	Gambar	2 Pintu	3 Pintu
Roda Atas (Plastik)		4	6
Roda Bawah (Plat Besi)		4	6
Damper		4	4
4*16 Sekrup Tapping Plus		32	48
Kunci Allen 2 mm		1	1

Video cara pemasangan:

SD-452 (2 Pintu)

SD-453 (3 Pintu)

SD-75

Roda Pintu Sliding

Material : Besi Plat
Roda : Nylon

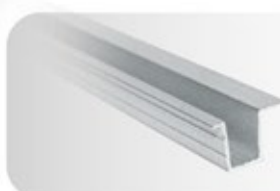
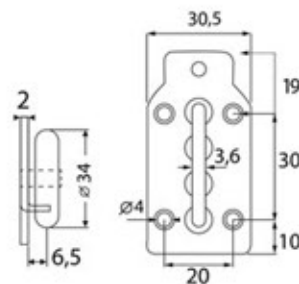
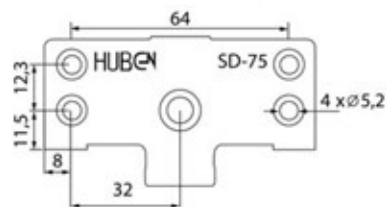

Rel Aluminium
AS-75
LAS-75

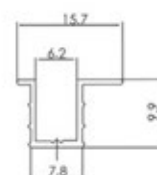

SD-753

Roda Pintu Sliding

Material : Besi Plat
Roda : Nylon

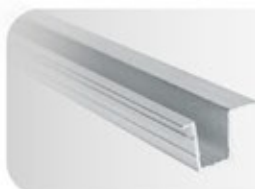
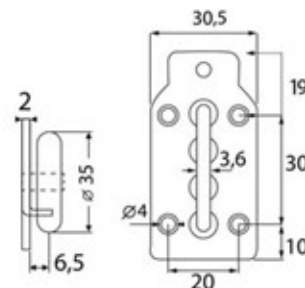
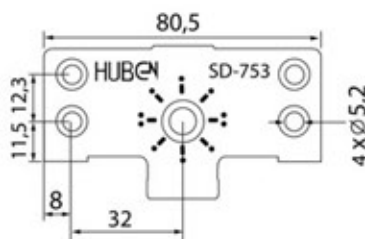

Rel Aluminium
AS-75
LAS-75

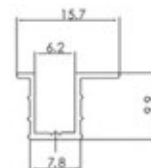

SD-380

Roda Pintu Sliding

Material : Besi Plat
Roda : Nylon

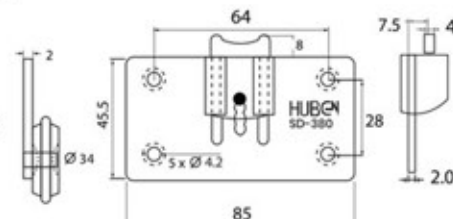
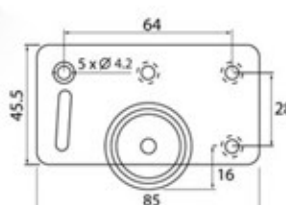

Rel Aluminium
AS-380
LAS-380

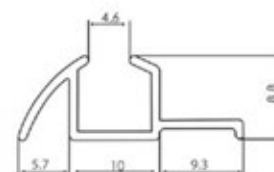



SD-12 Roda Pintu Sliding

Material : Zinc Alloy
Roda : Nylon

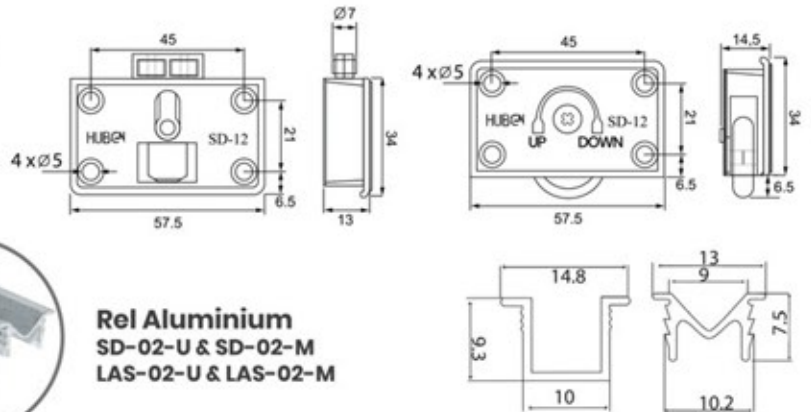

Rel Aluminium
SD-02-U & SD-02-M
LAS-02-U & LAS-02-M

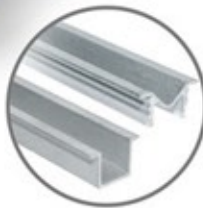

SD-338 Roda Pintu Sliding

Material : Nylon
Roda : Nylon

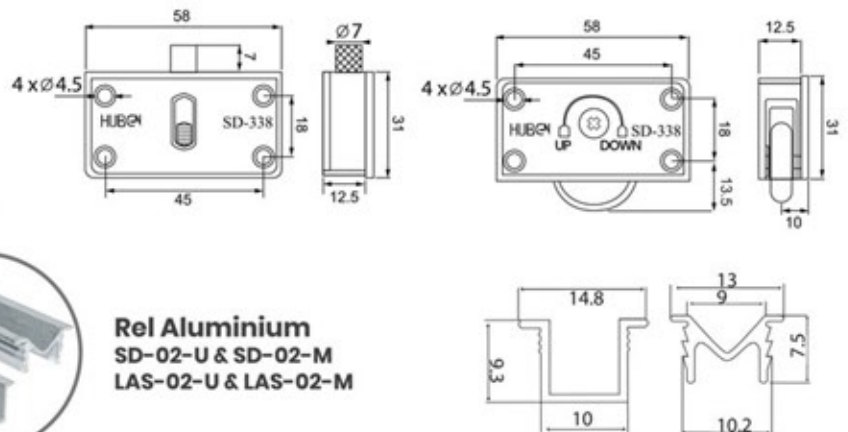

Rel Aluminium
SD-02-U & SD-02-M
LAS-02-U & LAS-02-M

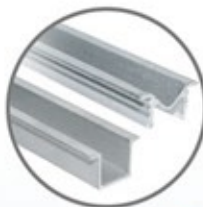

SD-3141 Roda Pintu Sliding

Material : Nylon
Roda : Nylon

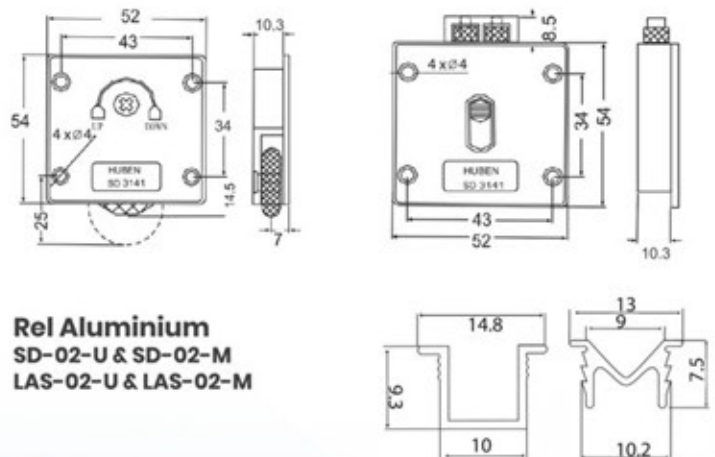

Rel Aluminium
SD-02-U & SD-02-M
LAS-02-U & LAS-02-M



HUBEN[®]
INSIDE

LENAGA[®]

FURNITURE FITTINGS & PVC SHEET



Huben Indonesia



www.hubenindonesia.com



info@huben.co.id